

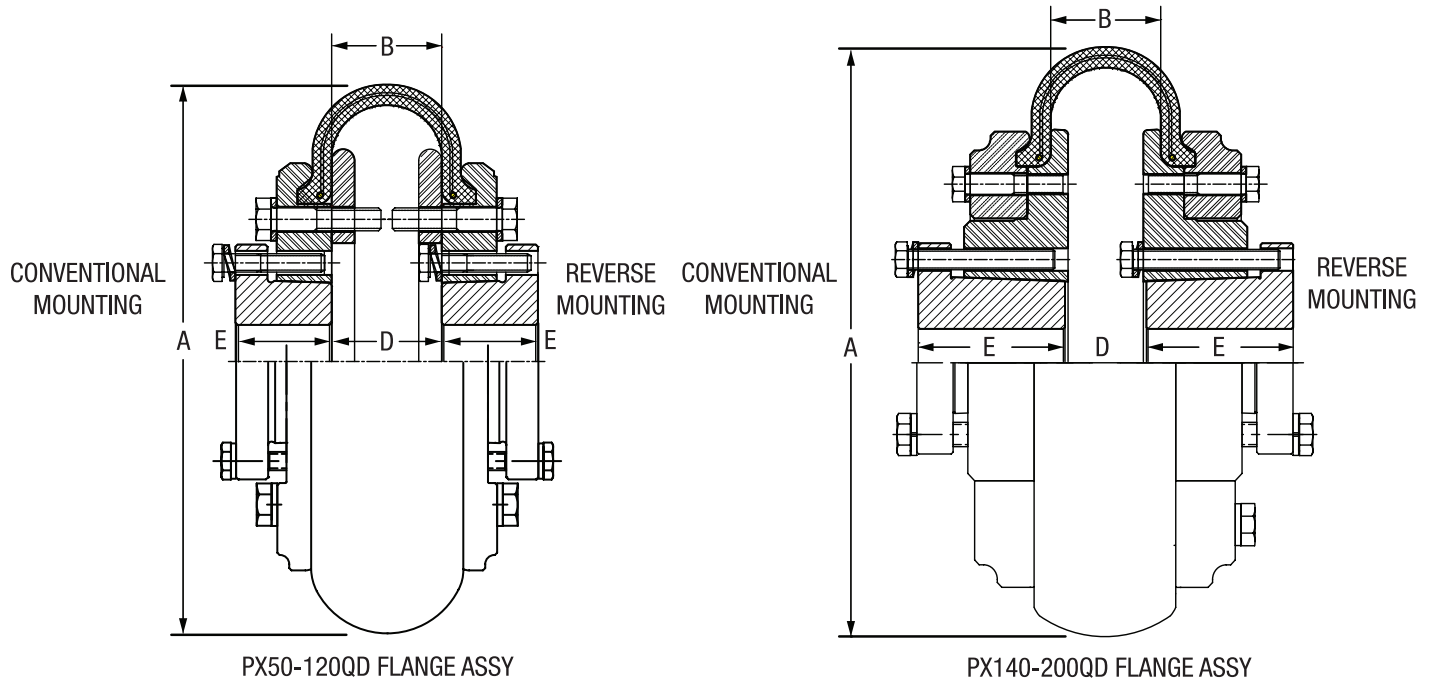

SELECTION/DIMENSIONS

Standard, QD Bushed



Dimensions

Coupling Size	Bushing Size	Max Bore (In.)			HP/100	Torque Rating (In-Lbs)	Max RPM	Style	Dimensions (In.)				Weight (1) (Lbs.)	Inertia (2) (Lb-Ft)
		Full KW	Shallow KW	No KW					A	B	D	E		
PX50QD	JA	1	1-3/16	1-1/4	1.43	900	4500	1	5 1/4	3 7/8	1	1 17/32	4.7	0.08
PX60QD	SH	1-3/8	1-5/8	1-11/16	2.86	1800	4000	1	6 1/2	4 23/32	1 1/4	1 25/32	8.0	0.24
PX70QD	SDS	1-5/8	1-15/16	2	3.49	2200	3600	1	7 3/8	4 17/32	1 5/16	1 1/2	10.7	0.45
PX80QD	SK	2-1/8	2-1/2	2-5/8	5.72	3600	3100	1	8 3/8	5 13/16	3 7/8	1 1/2	15.5	0.88
PX90QD	SK	2-1/8	2-1/2	2-5/8	7.15	4350	2800	1	9 1/4	5 7/8	3 7/8	1 9/16	22.0	1.60
PX100QD	SF	2-5/16	2-15/16	-	8.58	5250	2600	1	10	6 1/8	4 5/8	1 15/32	32.0	2.90
PX110QD	SF	2-5/16	2-15/16	-	12.3	7750	2300	1	11	5 7/8	4 5/8	1 3/16	46.0	4.30
PX120QD	E	2-7/8	3-1/2	-	20	12540	2100	1	12 3/8	7 1/4	6	1 1/4	59.8	6.70
PX140QD	F	3-1/4	3-15/16	4	44	27590	1840	2	14 1/8	9 1/2	6 5/8	1 3/8	132.5	19.50
PX160QD	J	3-3/4	4-1/2	-	60	37800	1560	2	16 5/8	11 1/2	7 1/4	1 3/8	208.7	34.60
PX200QD	J	3-3/4	4-1/2	-	131	82500	1300	2	20	11 3/4	7 1/4	1 13/16	366.0	103.00

- Notes:**
 (1) Weight of complete coupling with bushings.
 (2) Inertia of complete coupling with bushing.



SELECTION/DIMENSIONS

Standard, QD Bushed

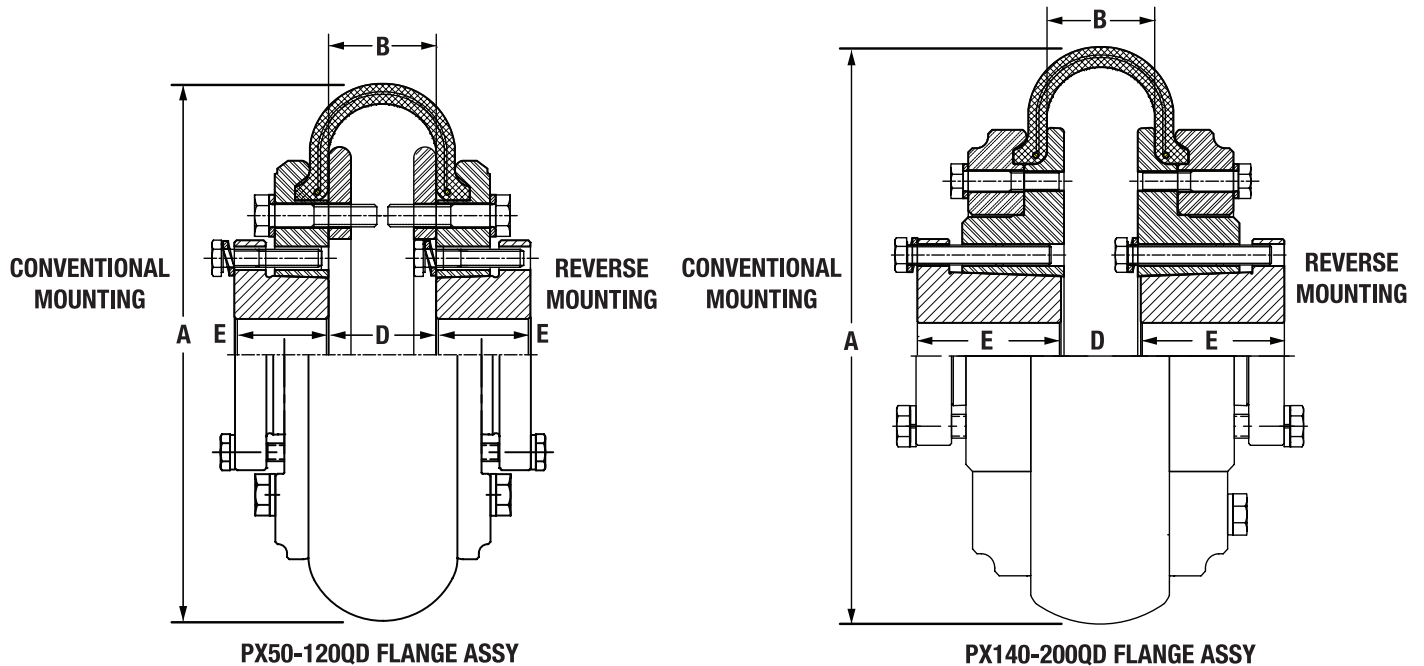

Para-Flex QD Part Numbers

Size	PXQD Flanges		Elements		
	Description	Part No.	Standard	Neoprene (1)	Cordless (2)
PX50	PX50QD FLANGE ASSEMBLY	013210	011105	011296	011285
PX60	PX60QD FLANGE ASSEMBLY	013211	011106	011297	011286
PX70	PX70QD FLANGE ASSEMBLY	013212	011107	011298	011287
PX80	PX80QD FLANGE ASSEMBLY	013213	011108	011299	011288
PX90	PX90QD FLANGE ASSEMBLY	013214	011109	011300	011289
PX100	PX100QD FLANGE ASSEMBLY	013215	011110	011301	011290
PX110	PX110QD FLANGE ASSEMBLY	013216	011111	011302	-
PX120	PX120QD FLANGE ASSEMBLY	013217	011112	011303	011292
PX140	PX140QD FLANGE ASSEMBLY	013218	011114	011304	-
PX160	PX160QD FLANGE ASSEMBLY	013219	011117	011305	-
PX200	PX200QD FLANGE ASSEMBLY	013220	011120	011306	-

Complete Para-Flex QD coupling consists of one element, two flanges, and two QD bushings.

Notes:

(1) Neoprene element ratings are the same as the standard natural rubber element ratings. (Green sticker or painted mark)

(2) Cordless elements have an average static torsional stiffness 25% of the standard element and approximately 25% of the torque rating. (White sticker or painted mark)

FEATURES/BENEFITS PAGE PT1-2	SPECIFICATION/HOW TO ORDER PAGE PT1-3	MODIFICATION/ACCESSORIES PAGE PT1-79	ENGINEERING/TECHNICAL PAGE PT1-81
---------------------------------	--	---	--------------------------------------