

Fenaflex® Couplings - Power Ratings



POWER RATINGS (KW)

Speed rev/min	Coupling Size														
	F40	F50	F60	F70	F80	F90	F100	F110	F120	F140	F160	F180	F200	F220	F250
100	0.25	0.69	1.33	2.62	3.93	5.24	7.07	9.16	13.9	24.3	39.5	65.7	97.6	121.0	154.0
200	0.50	1.38	2.66	5.24	7.85	10.50	14.10	18.30	27.9	48.7	79.0	131.0	195.0	243.0	307.0
300	0.75	2.07	3.99	7.85	11.80	15.70	21.20	27.50	41.8	73.0	118.0	197.0	293.0	364.0	461.0
400	1.01	2.76	5.32	10.50	15.70	20.90	28.30	36.60	55.7	97.4	158.0	263.0	391.0	486.0	615.0
500	1.26	3.46	6.65	13.10	19.60	26.20	35.30	45.80	69.6	122.0	197.0	328.0	488.0	607.0	768.0
600	1.51	4.15	7.98	15.70	23.60	31.40	42.40	55.00	83.6	146.0	237.0	394.0	586.0	729.0	922.0
700	1.76	4.84	9.31	18.30	27.50	36.60	49.50	64.10	97.5	170.0	276.0	460.0	684.0	850.0	1076.0
<b>720</b>	<b>1.81</b>	<b>4.98</b>	<b>9.57</b>	<b>18.80</b>	<b>28.30</b>	<b>37.70</b>	<b>50.90</b>	<b>66.00</b>	<b>100.0</b>	<b>175.0</b>	<b>284.0</b>	<b>473.0</b>	<b>703.0</b>	<b>875.0</b>	<b>1106.0</b>
800	2.01	5.53	10.60	20.90	31.40	41.90	56.50	73.30	111.0	195.0	316.0	525.0	781.0	972.0	1229.0
900	2.26	6.22	12.00	23.60	35.30	47.10	63.60	82.50	125.0	219.0	355.0	591.0	879.0	1093.0	1383.0
<b>960</b>	<b>2.41</b>	<b>6.63</b>	<b>12.80</b>	<b>25.10</b>	<b>37.70</b>	<b>50.30</b>	<b>67.90</b>	<b>88.00</b>	<b>134.0</b>	<b>234.0</b>	<b>379.0</b>	<b>630.0</b>	<b>937.0</b>	<b>1166.0</b>	<b>1475.0</b>
1000	2.51	6.91	13.30	26.20	39.30	52.40	70.70	91.60	139.0	243.0	395.0	657.0	976.0	1215.0	1537.0
1200	3.02	8.29	16.00	31.40	47.10	62.80	84.80	110.00	167.0	292.0	474.0	788.0	1172.0		
1400	3.52	9.68	18.60	36.60	55.00	73.30	99.00	128.00	195.0	341.0	553.0	919.0			
<b>1440</b>	<b>3.62</b>	<b>9.95</b>	<b>19.10</b>	<b>37.70</b>	<b>56.50</b>	<b>75.40</b>	<b>102.00</b>	<b>132.00</b>	<b>201.0</b>	<b>351.0</b>	<b>568.0</b>	<b>945.0</b>			
1600	4.02	11.10	21.30	41.90	62.80	83.80	113.00	147.00	223.0	390.0	632.0				
1800	4.52	12.40	23.90	47.10	70.70	94.20	127.00	165.00	251.0	438.0					
2000	5.03	13.80	26.60	52.40	78.50	105.50	141.00	183.00	279.0						
2200	5.53	15.20	29.30	57.60	86.40	115.00	155.00	202.00							
2400	6.03	16.60	31.90	62.80	94.20	126.00	170.00								
2600	6.53	18.00	34.60	68.10	102.00	136.00	184.00								
2800	7.04	19.40	37.20	73.30	110.00	147.00									
<b>2880</b>	<b>7.24</b>	<b>19.90</b>	<b>38.30</b>	<b>75.40</b>	<b>113.00</b>	<b>151.00</b>									
3000	7.54	20.70	39.90	78.50	118.00	157.00									
3600	9.05	24.90	47.90	94.20											

The figures in heavier type are for standard motor speeds. All these power ratings are calculated at constant torque. For speeds below 100 rev/min and intermediate speeds use nominal torque ratings.

PHYSICAL CHARACTERISTICS – FLEXIBLE TYRES

Characteristics	Coupling Size														
	F40	F50	F60	F70	F80	F90	F100	F110	F120	F140	F160	F180	F200	F220	F250
Maximum speed rev/min	4,500	4,500	4,000	3,600	3,100	3,000	2,600	2,300	2,050	1,800	1,600	1,500	1,300	1,100	1,000
Nominal Torque Nm T <sub>KN</sub>	24	66	127	250	375	500	675	875	1,330	2,325	3,770	6,270	9,325	11,600	14,675
Maximum Torque Nm T <sub>K MAX</sub>	64	160	318	487	759	1,096	1,517	2,137	3,547	5,642	9,339	16,455	23,508	33,125	42,740
Torsional Stiffness Nm/°	5	13	26	41	63	91	126	178	296	470	778	1,371	1,959	2,760	3,562
Max. parallel misalignment mm	1.1	1.3	1.6	1.9	2.1	2.4	2.6	2.9	3.2	3.7	4.2	4.8	5.3	5.8	6.6
Maximum end float mm ±	1.3	1.7	2.0	2.3	2.6	3.0	3.3	3.7	4.0	4.6	5.3	6.0	6.6	7.3	8.2
Approximate mass. kg	0.1	0.3	0.5	0.7	1.0	1.1	1.1	1.4	2.3	2.6	3.4	7.7	8.0	10.0	15.0
Alternating Torque ± Nm @ 10Hz T <sub>KW</sub>	11	26	53	81	127	183	252	356	591	940	1,556	2,742	3,918	5,521	7,124
Resonance Factor V <sub>R</sub>	7	7	7	7	7	7	7	7	7	7	7	7	7	7	7
Damping Coefficient Ψ	0.9	0.9	0.9	0.9	0.9	0.9	0.9	0.9	0.9	0.9	0.9	0.9	0.9	0.9	0.9

Maximum torque figures should be regarded as short duration overload ratings for use in such circumstances as direct-on-line motor starting.

All Fenaflex tyre couplings have an angular misalignment capacity up to 4°.

FLEXIBLE TYRE CODE NUMBERS

Unless otherwise specified Fenaflex flexible tyres will be supplied in a natural rubber compound which is suitable for operation in temperatures -50°C to +50°C. A chloroprene compound is available which is Fire Resistant and Anti-Static (FRAS) and has greater resistance to heat and oil.

This is suitable for operation in temperatures -15°C to +70°C. For temperatures outside these ranges – consult your local Authorised Distributor.

The FRAS tyre variant is used with specifically modified metal flanges to create the ATEX approved variant.

Size	Natural	FRAS	Coupling Size	M Dimension (mm)	Gap Between Tyre Ends (mm)	Clamping Screw Torque (Nm)	Screw Size
F40	033A0048	033A0068					
F50	033B0048	033B0068	F40*	22	2	15	M6
F60	033C0048	033C0068	F50*	25	2	15	M6
F70	033D0048	033D0068	F60*	33	2	15	M6
F80	033E0048	033E0068	F70	23	3	24	M8
F90	033F0048	033F0068	F80	25	3	24	M8
F100	033G0048	033G0068	F90	27	3	40	M10
F110	033H0048	033H0068	F100	27	3	40	M10
F120	033J0048	033J0068	F110	25	3	40	M10
F140	033K0048	033K0068	F120	29	3	50	M12
F160	033L0048	033L0068	F140	32	5	55	M12
F180	033Q0048	033Q0068	F160	30	5	80	M16
F200	033M0048	033M0068	F180	46	6	105	M16
F220	033N0048	033N0068	F200	48	6	120	M16
F250	033P0048	033P0068	F220	55	6	165	M20
			F250	59	6	165	M20

\*Hexagonal socket caphead clamping screws on these sizes.

FLANGES

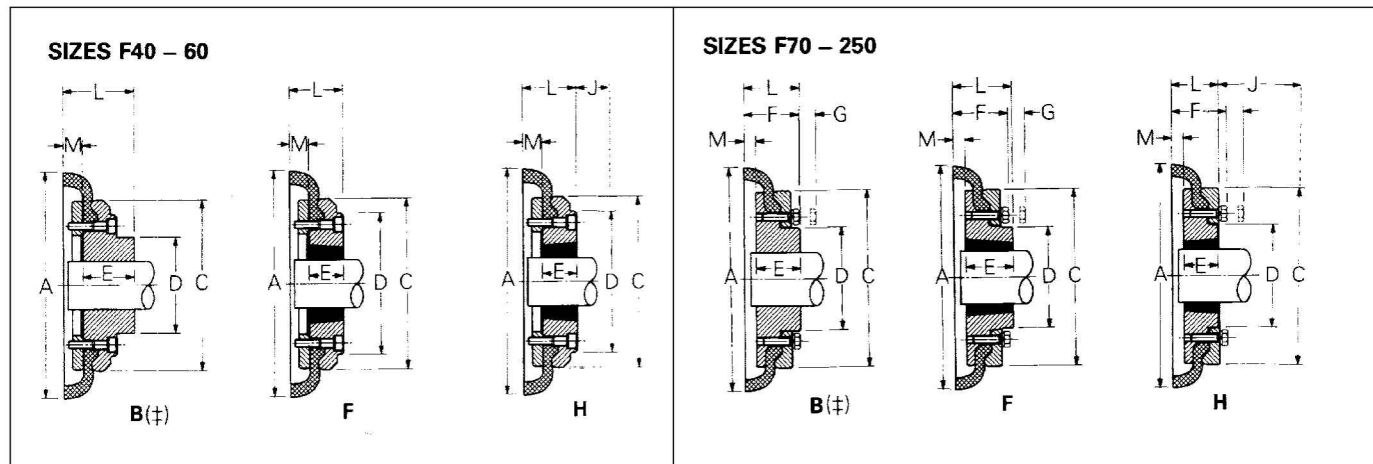

DIMENSIONS OF FENAFLEX FLANGES TYPES B, F & H

Catalogue # Code	Size	Type	Bush No. #	Max Bore		Types F & H			Type B		Screw over Key	A	C	D	F	G§	M¶	Mass* (kg)	Inertia* (kgm²)
				Metric	Inch	L	E	J†	L	E									
033A0501	<b>F40</b>	B	-	32	-	-	-	29	33.0	22	M5	104	82	-	-	-	11.0	0.8	0.00074
033A0502	<b>F40</b>	F	1008	25	1"	33.0	22	29	-	-	-	104	82	-	-	-	11.0	0.8	0.00074
033A0503	<b>F40</b>	H	1008	25	1"	33.0	22	29	-	-	-	104	82	-	-	-	11.0	0.8	0.00074
033B0501	<b>F50</b>	B	-	38	-	-	-	38	45.0	32	M5	133	100	79	-	-	12.5	1.2	0.00115
033B0502	<b>F50</b>	F	1210	32	1 1/4"	38.0	25	38	-	-	-	133	100	79	-	-	12.5	1.2	0.00115
033B0503	<b>F50</b>	H	1210	32	1 1/4"	38.0	25	38	-	-	-	133	100	79	-	-	12.5	1.2	0.00115
033C0501	<b>F60</b>	B	-	45	-	-	-	38	55.0	38	M6	165	125	70	-	-	16.5	2.0	0.0052
033C0502	<b>F60</b>	F	1610	42	1 5/8"	42.0	25	38	-	-	-	165	125	103	-	-	16.5	2.0	0.0052
033C0503	<b>F60</b>	H	1610	42	1 5/8"	42.0	25	38	-	-	-	165	125	103	-	-	16.5	2.0	0.0052
033D0301	<b>F70</b>	B	-	50	-	-	-	42	47.0	35	M10	187	144	80	50	13	11.5	3.1	0.009
033D0302	<b>F70</b>	F	2012	50	2"	44.0	32	42	-	-	-	187	144	80	50	13	11.5	3.1	0.009
033D0303	<b>F70</b>	H	1610	42	1 5/8"	42.0	25	38	-	-	-	187	144	80	50	13	11.5	3.0	0.009
033E0301	<b>F80</b>	B	-	60	-	-	-	48	55.0	42	M10	211	167	98	54	16	12.5	4.9	0.018
033E0302	<b>F80</b>	F	2517	60	2 1/2"	58.0	45	48	-	-	-	211	167	97	54	16	12.5	4.9	0.018
033E0303	<b>F80</b>	H	2012	50	2"	45.0	32	42	-	-	-	211	167	98	54	16	12.5	4.6	0.017
033F0301	<b>F90</b>	B	-	70	-	-	-	55	63.5	49	M12	235	188	112	60	16	13.5	7.1	0.032
033F0302	<b>F90</b>	F	2517	60	2 1/2"	59.5	45	48	-	-	-	235	188	108	60	16	13.5	7.0	0.031
033F0303	<b>F90</b>	H	2517	60	2 1/2"	59.5	45	48	-	-	-	235	188	108	60	16	13.5	7.0	0.031
033G0301	<b>F100</b>	B	-	80	-	-	-	55	70.5	56	M12	254	216	125	62	16	13.5	9.9	0.055
033G0302	<b>F100</b>	F	3020	75	3"	65.5	51	55	-	-	-	254	216	120	62	16	13.5	9.9	0.055
033G0303	<b>F100</b>	H	2517	60	2 1/2"	59.5	45	48	-	-	-	254	216	113	62	16	13.5	9.4	0.054
033H0301	<b>F110</b>	B	-	90	-	-	-	55	75.5	63	M12	279	233	128	62	16	12.5	12.5	0.081
033H0302	<b>F110</b>	F	3020	75	3"	63.5	51	55	-	-	-	279	233	134	62	16	12.5	11.7	0.078
033H0303	<b>F110</b>	H	3020	75	3"	63.5	51	55	-	-	-	279	233	134	62	16	12.5	11.7	0.078
033J0301	<b>F120</b>	B	-	100	-	-	-	55	84.5	70	M16	314	264	143	67	16	14.5	16.9	0.137
033J0302	<b>F120</b>	F	3525	100	4"	79.5	65	67	-	-	-	314	264	140	67	16	14.5	16.5	0.137
033J0303	<b>F120</b>	H	3020	75	3"	65.5	51	55	-	-	-	314	264	140	67	16	14.5	15.9	0.130
033K0301	<b>F140</b>	B	-	130	-	-	-	67	110.5	94	M20	359	311	178	73	17	16.0	22.2	0.254
033K0302	<b>F140</b>	F	3525	100	4"	81.5	65	67	-	-	-	359	311	178	73	17	16.0	22.3	0.255
033K0303	<b>F140</b>	H	3525	100	4"	81.5	65	67	-	-	-	359	311	178	73	17	16.0	22.3	0.255
033L0301	<b>F160</b>	B	-	140	-	-	-	77	117	102	M20	402	345	187	78	19	15.0	35.8	0.469
033L0302	<b>F160</b>	F	4030	115	4 1/2"	92.0	77	80	-	-	-	402	345	197	78	19	15.0	32.5	0.380
033L0303	<b>F160</b>	H	4030	115	4 1/2"	92.0	77	80	-	-	-	402	345	197	78	19	15.0	32.5	0.380
033Q0301	<b>F180</b>	B	-	150	-	-	-	89	137	114	M20	470	398	200	94	19	23.0	49.1	0.871
033Q0302	<b>F180</b>	F	4535	125	5"	112.0	89	89	-	-	-	470	398	205	94	19	23.0	42.2	0.847
033Q0303	<b>F180</b>	H	4535	125	5"	112.0	89	89	-	-	-	470	398	205	94	19	23.0	42.2	0.847
033M0301	<b>F200</b>	B	-	150	-	-	-	89	138	114	M20	508	429	200	103	19	24.0	58.2	1.301
033M0302	<b>F200</b>	F	4535	125	5"	113.0	89	89	-	-	-	508	429	205	103	19	24.0	53.6	1.281
033M0303	<b>F200</b>	H	4535	125	5"	113.0	89	89	-	-	-	508	429	205	103	19	24.0	53.6	1.281
033N0301	<b>F220</b>	B	-	160	-	-	-	92	154.5	127	M20	562	474	218	118	20	27.5	79.6	2.142
033N0302	<b>F220</b>	F	5040	125	5"	129.5	102	92	-	-	-	562	474	223	118	20	27.5	72.0	2.104
033N0303	<b>F220</b>	H	5040	125	5"	129.5	102	92	-	-	-	562	474	223	118	20	27.5	72.0	2.104
033P0301	<b>F250</b>	B	-	190	-	-	-	92	161.5	132	M20	628	532	254	125	25	29.5	104.0	3.505

Dimensions in millimetres unless otherwise stated.

§ G is the amount by which clamping screws need to be withdrawn to release tyre.

† J is the wrench clearance to allow for tightening/loosening the bush on the shaft and the clamp ring screws on sizes F40, F50 and F60. The use of a shortened wrench will allow this dimension to be reduced.

¶ M is half the distance between flanges. Shaft ends, although normally located twice M apart, can project beyond the flanges as shown. In this event allow sufficient space between shaft ends for end float and misalignment.

\* Mass and inertia figures are for single flange with mid range bore and include clamping ring, screws and washers and half tyre.

‡ For pilot bore 'B' flange code as listed. Flanges are also available finish bored with keyway if required. Bore must be specified on order.

# Note: On sizes F70, 80, 100 and 120 the 'F' direction bush is larger than that in the 'H' direction.

Note: Flange assemblies comprise hub, clamp ring and clamp ring screws/washers.