

# Type G20 Standard Flanged Sleeve Double Engagement

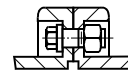
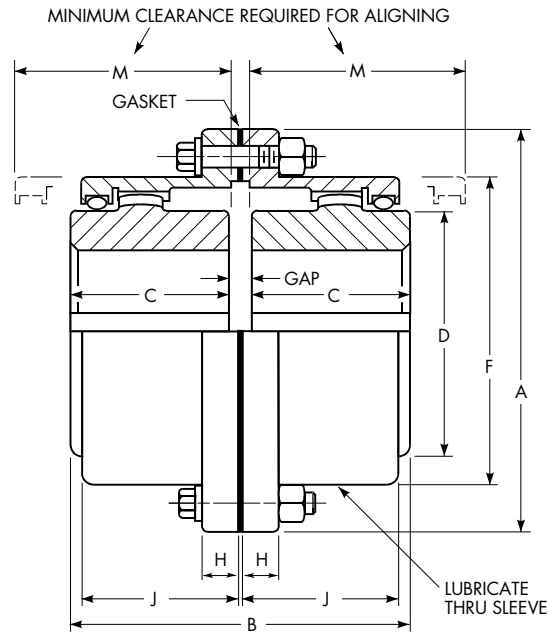

For Sizes 1010G thru 1055G,  
Type G10 Shrouded Bolts furnished  
only when specified on order

## Dimensions (in)

Size ①	Torque Rating (lb-in) ④	Allow Speed RPM ⑤	Max Bore ⑥	Min Bore ⑦	Cplg Wt With No Bore (lb)		Lube Wt (lb)	A	B	C	D	F	H	J	M	GAP
					G10	G20										
1010G	10,080	8,000	1.875	0.50	9	10	0.09	4.56	3.50	1.69	2.70	3.30	0.55	1.53	2.00	0.125
1015G	20,790	6,500	2.375	0.75	17	20	0.16	6.00	4.00	1.94	3.40	4.14	0.75	1.88	2.40	0.125
1020G	37,800	5,600	2.875	1.00	30	35	0.25	7.00	5.00	2.44	4.14	4.98	0.75	2.34	3.00	0.125
1025G	66,150	5,000	3.625	1.25	55	65	0.50	8.38	6.25	3.03	5.14	6.10	0.86	2.82	3.60	0.188
1030G	107,100	4,400	4.125	1.50	85	95	0.80	9.44	7.37	3.59	6.00	7.10	0.86	3.30	4.20	0.188
1035G	163,800	3,900	4.875	2.00	135	150	1.20	11.00	8.63	4.19	7.00	8.32	1.12	3.84	5.10	0.250
1040G	270,900	3,600	5.750	2.50	195	215	2.00	12.50	9.75	4.75	8.25	9.66	1.12	4.38	5.70	0.250
1045G	371,700	3,200	6.750	3.00	280	300	2.30	13.62	10.93	5.31	9.25	10.79	1.12	4.84	6.50	0.312
1050G	500,900	2,900	7.375	3.50	390	420	3.90	15.31	12.37	6.03	10.00	12.04	1.50	5.54	7.20	0.312
1055G	655,200	2,650	8.250	4.00	525	550	4.90	16.75	13.56	6.62	11.00	13.16	1.50	6.22	8.00	0.312
1060G	800,100	2,450	9.125	4.50	—	675	7.00	18.00	15.13	7.41	12.00	14.41	1.00	6.66	9.00	0.312
1070G	1,197,000	2,150	10.875	5.00	—	1070	9.60	20.75	17.75	8.69	14.00	16.73	1.12	7.70	10.50	0.375

Table 7 — Limited End Float & Standard Gap Disc Dimensions (in)

Size	B	End Float ②	Gap Disc ③		GAP
			Thickness	Dia	
1010G	3.58	0.094	0.156	2.95	0.203
1015G	4.08	0.094	0.156	3.70	0.203
1020G	5.11	0.094	0.188	4.50	0.234
1025G	6.39	0.094	0.281	5.55	0.328
1030G	7.54	0.094	0.312	6.50	0.359
1035G	8.79	0.188	0.312	7.55	0.406
1040G	9.91	0.188	0.312	8.95	0.406
1045G	11.15	0.188	0.438	9.95	0.531
1050G	12.59	0.188	0.438	10.95	0.531
1055G	13.80	0.188	0.469	12.00	0.563
1060G	15.45	0.188	0.532	13.12	0.625
1070G	18.10	0.188	0.625	15.10	0.718

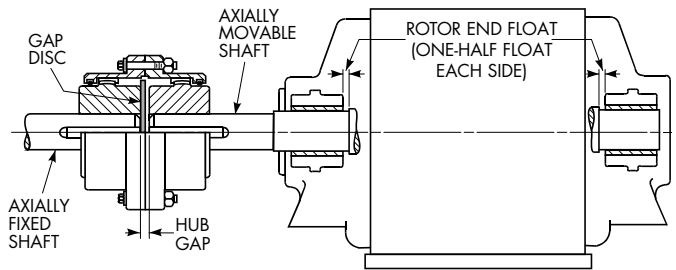

- ① See page 11 for General Information.
- ② If these values exceed one-half rotor end float or equivalent manufacturer's specification, refer to the Factory.
- ③ Gap disc material: Neoprene, 70 durometer.
- ④ Peak torque capacity is two times the published rating.
- ⑤ Consult Factory for higher speeds. Balancing may allow up to a 50% increase in speeds shown. Consult Factory or I & M manual for min. speeds with LTG NLG1 greases.
- ⑥ Maximum bores are reduced for hubs furnished with an interference fit and a setscrew over the keyway. Maximum bores may also be reduced when puller bolt holes are required. Refer to Table 13 and Table 14 on page 43. Bore capacities can be increased beyond values shown if the coupling torque rating is reduced. Refer to the Factory. Recommended key sizes for the listed maximum bores are shown in Table 37, page 52, and Table 23, page 47.
- ⑦ Minimum bore is the smallest bore to which a Rough Stock Bore (RSB) hub can be bored. Depending upon coupling size, RSB hubs may have only a blind centering hole or a through hole that will permit remachining of the hubs to the minimum bores specified.