



Design Features include:

- Split-in-half flex element design for simplified assembly and disassembly
- Torsionally soft flex element cushions shock loads and vibration, extending equipment life
- Interchangeable hubs allow for reduced inventory
- Polyurethane-to-metal bond eliminates assembly and slippage problems associated with mechanically clamped designs
- Material flexing design allows visual inspection during operation
- Element "V" Notch design provides a uniform failure area for overload protection if required

Applications:

- Pumps
- Compressors
- Industrial fans
- Mixers

Industry Compliant:

- ATEX II 2GD c T5

Special design options:

- Rexnord Viva Spline Bore Hub
- Rexnord Viva Positive Drive Coupling
- Rexnord Viva Keyless Hub / Bushing Design
- Limited end float
- Bolt-on brake

Rexnord Viva V Elastomer Coupling

Customer-focused solutions.

Reliable Performance.

Trusted Brands.

You want a trusted name when it comes to providing engineered power transmission products that improve productivity and efficiency. Rexnord® provides superior products for your industrial applications world wide. We work closely with you to reduce maintenance costs, eliminate redundant inventories and prevent equipment downtime.

Rexnord Viva V

The Rexnord Viva® is a unique general purpose elastomer coupling with split element design providing easy assembly and replace-in-place service. Available in close coupled and spacer designs. These unique designs permit faster installation and reduced inventories by providing multiple distance between shaft ends using the same elements and hubs. Rexnord Viva V design is used on close coupled applications.



ATEX II 2GD c T5



Torque Demands Driven Machine	Typical Application for Electric Motor or Turbine Driven Equipment	Typical Service Factor
	Constant torque such as centrifugal pumps blowers and compressors	1.0
	Continuous duty with some torque variations including plastic extruders and forced draft fans	1.5
	Light shock loads from metal extruders, cooling towers and log haulers	2.0
	Moderate shock loading as expected from a car dumper, stone crusher, vibrating screen	2.5
	Heavy shock load with some negative torques from reciprocating pumps, compressors, reversing turnout tables	3.0
	Frequent torque reversals such as reciprocating compressors with frequent torque reversals which do not necessarily include reverse rotations	Consult Rexnord Engineering

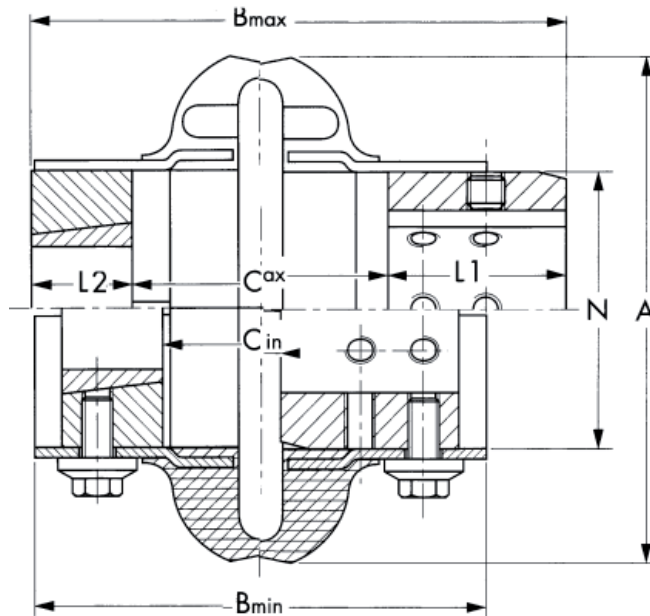

Coupling size	Tnom Nm	n max min-1	D1 Dmax mm	D2 Taper Bush mm	Dmax mm	A mm	B min. mm	B max. mm	C(1) min. mm	C(1) max. mm	C(2) min. mm	C(2) max. mm	L1 mm	L2 mm	N mm	m* kg	J* kgm ²
110	62	5 400	38	1 108	28	110	97	132	9	55	41	55	38	22	60	1,4	0,00123
125	105	5 400	48	1 108	28	125	98	132	9	55	41	55	38	22	70	1,7	0,00202
130	164	5 100	55	1 310	35	130	97	142	7	55	35	55	41	25	80	2,1	0,00310
150	250	4 800	65	1 610	42	150	111	156	9	60	54	66	51	25	95	4,2	0,00900
170	308	4 800	65	1 610	42	170	111	156	9	60	54	66	51	25	95	4,3	0,00931
190	412	4 600	75	2 012	50	190	116	164	7	60	47	60	52	32	114	5,5	0,0173
215	662	4 300	80	2 517	60	215	134	191	11	64	51	61	64	45	140	10	0,0303
245	938	4 100	95	3 020	75	245	137	202	7	73	50	57	65	51	171	14	0,076
290	1 412	3 900	110	3 020	75	290	153	241	8	94	40	87	73	51	215	25	0,192
365	3 200	3 600	127	3 535	90	365	200	311	20	131	20	131	90	90	235	42	0,373
425	5 580	2 000	155	4 040	100	425	247	361	19	133	44	132	114	102	285	85	1,180
460	6 270	2 000	165	4 545	110	460	267	380	19	132	38	132	124	114	302	93	1,720

*weight (m) and inertia (J) with maximum bore and key way • Dimension (C1) finished bore hubs - C(2) with Taper Bush hubs