

Spacer Coupling GP Series - Form-Flex®

Double Flex Spacer

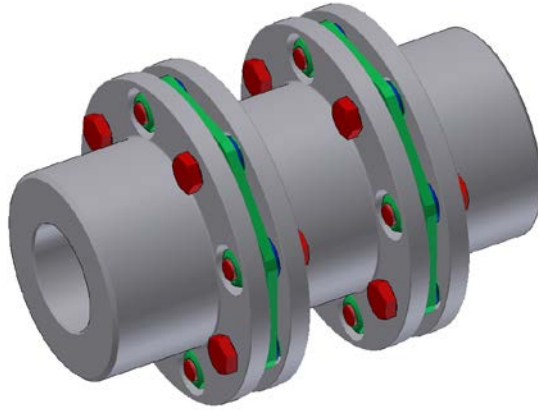

Size	Torque Rating			Max Speed (RPM)		Weight (lbs) (1)		WR ² (lb-in ²) (1)		Misalign-ment Capacity	
	HP / 100 (RPM)	Max Continuous (lb-in)	Peak Overload (lb-in)	AGMA 8	ABS. Max	at D Min	Add Per Inch of D	at D Min	Add Per Inch of D	Axial (+/- in)	Angular (Degrees/ Disc Pack)
311	17	11,000	22,000	5,400	13,000	16.20	0.62	66.70	2.09	0.028	0.5°
321	33	20,500	41,000	4,900	12,000	25.75	0.66	123.01	2.54	0.029	
332	51	32,000	64,000	4,400	11,500	40.27	0.94	242.39	4.27	0.030	
346	73	46,000	92,000	4,100	9,000	54.42	1.03	429.27	6.94	0.050	
380	127	80,000	160,000	3,800	7,000	79.30	1.20	792.67	8.75	0.080	
412	190	120,000	240,000	3,500	6,000	110.1	1.45	1607.6	13.29	0.080	0.33°
419	301	190,000	380,000	3,000	5,000	197.8	2.32	3660.0	27.92	0.100	
424	476	300,000	600,000	2,750	5,000	287.6	3.08	8127.6	62.49	0.100	
444	690	435,000	870,000	2,500	4,000	413.3	3.38	13587	87.03	0.110	
456	1015	640,000	1,280,000	2,350	3,500	539	4.73	21896	133.5	0.120	
483	1317	830,000	1,660,000	2,200	3,500	727	5.36	33653	195.1	0.130	
511	1904	1,200,000	2,400,000	2,050	3,000	978	6.75	60082	310.3	0.140	
520	3173	2,000,000	4,000,000	1,750	2,500	1752	10.14	114979	586.5	0.180	
525	3967	2,500,000	5,000,000	1,700	2,500	2113	11.07	185975	762.5	0.200	
530	4760	3,000,000	6,000,000	1,600	2,500	2533	15.43	243383	1160.9	0.200	
540	6347	4,000,000	8,000,000	1,450	2,000	3831	19.23	557906	2247.7	0.240	

1) Weight and WR² values shown are for standard hubs at max inch bore and spacer length at D Min

STANDARD MATERIALS

HUBS - CARBON STEEL

SPACER - CARBON STEEL

HARDWARE - ALLOY STEEL

DISC PACK - STAINLESS STEEL

MATERIAL / FINISH OPTIONS

DISC PACK - ALLOY STEEL (For cost reduction, available for sizes 412 to 540)

ZINC ELECTRO PLATING

ZINC PHOSPHATE COATING

ALLOY STEEL HUBS

Spacer Coupling GP Series - Form-Flex®

Double Flex Spacer

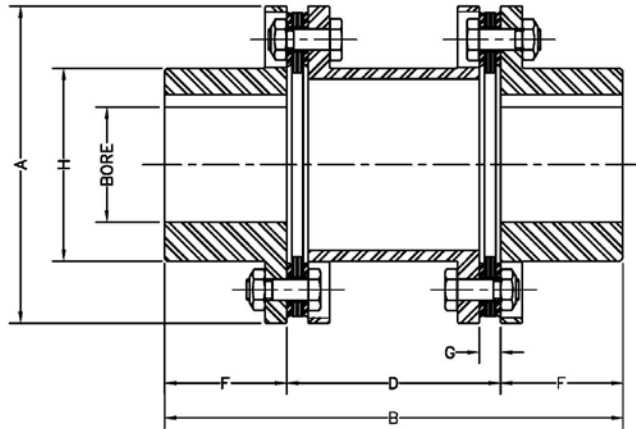

COUPLING CAN BE SUPPLIED
TO API610 11TH EDITION

Size	Max Bore						Common Coupling Dimensions (in)								
	Standard Hub			Oversized/Large Hub			A	B		D DBSE		F	G	H	
	Square Key (in)	Rect. Key (in)	Rect. Key (mm)	Square Key (in)	Rect. Key (in)	Rect. Key (mm)		Min	Max	Min	Max			Std Hub	O/S Hub
311	2.813	3.063	78	3.125	3.313	86	5.88	8.06	17.75	3.06	12.75	2.50	0.40	3.91	4.30
321	3.000	3.250	83	3.250	3.438	90	6.38	10.13	19.06	4.13	13.06	3.00	0.55	4.25	4.57
332	3.188	3.313	87	3.438	3.688	95	7.20	11.00	19.19	5.00	13.19	3.50	0.61	4.50	4.95
346	3.750	4.000	107	4.250	4.500	117	8.20	11.00	25.19	5.00	19.19	3.75	0.62	5.42	5.95
380	3.750	4.000	105	4.250	4.500	118	9.36	15.00	28.00	6.75	19.75	4.13	0.89	5.65	6.30
412	4.500	4.500	120	4.750	5.125	135	11.00	14.19	27.94	5.69	19.44	4.25	0.75	6.51	7.20
419	4.500	4.875	130	5.500	5.625	150	12.50	17.69	29.94	7.69	19.94	5.00	0.98	7.32	8.07
424	6.625	6.880	190				15.00	20.19	32.44	7.69	19.94	6.25	0.98	9.57	
444	7.000	7.375	200				16.38	22.75	34.13	8.75	20.13	7.00	1.09	10.52	
456	8.000	8.000	220				18.00	24.31	35.13	9.81	20.63	7.25	1.32	11.63	
483	8.250	8.875	234				19.44	27.69	37.75	10.69	20.75	8.50	1.39	12.56	
511	10.000	10.125	280				22.00	29.69	39.06	11.69	21.06	9.00	1.56	14.50	
520	10.375	11.000	297				24.88	38.50	45.50	14.75	21.75	11.88	1.89	15.96	
525	11.000	12.000	322				26.75	39.38	45.88	15.38	21.88	12.00	1.95	17.35	
530	11.500	12.750	338				28.00	41.88	47.75	16.38	22.25	12.75	2.14	18.35	
540	15.750	17.000	448				33.50	49.00	54.13	19.00	24.13	15.00	2.58	22.63	

ORDERING

GP SERIES COUPLINGS ARE SOLD AS COMPLETE ASSEMBLIES
PLEASE SPECIFY BORE SIZES, DISC PACK MATERIAL AND DBSE.
A COUPLING WILL BE CONFIGURED TO MEET YOUR SPECIFICATIONS.