

# Vertically Split Cover Couplings

## Series 1000T20

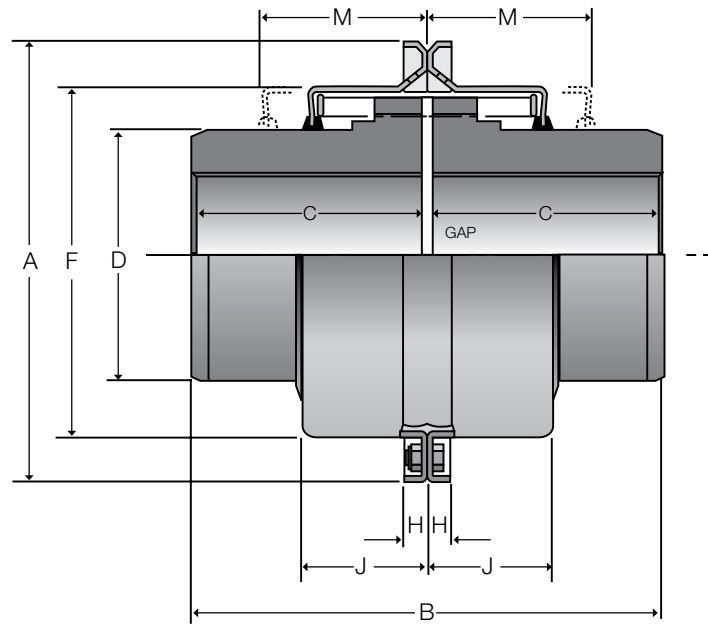

SIZE	COUPLING RATING (IN-LBS)	MAX RPM	MIN BORE (IN)	MAX BORE (IN)**	CPLG WT (LBS)*	WR2/ (LB/ FT2)*	DIMENSIONS IN INCHES								
							A	B	C	D	F	H	J	M	GAP
1020	460	6000	0.50	1.13	3.5	3.8	4.37	3.86	1.87	1.56	2.48	0.37	0.96	1.89	0.13
1030	1,319	6000	0.50	1.38	4.9	6.2	4.76	3.86	1.87	1.94	2.83	0.37	0.99	1.89	0.13
1040	2,204	6000	0.50	1.63	6.6	9.2	5.08	4.13	2.00	2.25	3.15	0.37	1.02	2.01	0.13
1050	3,850	6000	0.50	1.88	11	22	5.83	4.88	2.37	2.63	3.82	0.51	1.24	2.40	0.13
1060	6,054	6000	0.75	2.13	15	34	6.38	5.12	2.50	3.00	4.33	0.51	1.27	2.52	0.13
1070	8,798	5500	0.75	2.50	21	55	6.81	6.14	3.00	3.44	4.76	0.51	1.33	2.64	0.13
1080	18,144	4750	1.06	3.00	37	133	7.87	7.13	3.50	4.13	5.87	0.51	1.74	3.50	0.13
1090	33,013	4000	1.06	3.50	52	246	9.13	7.87	3.87	4.87	6.61	0.51	1.86	3.78	0.13
1100	55,582	3250	1.63	4.00	87	588	10.51	9.69	4.75	5.59	7.80	0.63	2.37	4.76	0.19
1110	82,489	3000	1.63	4.50	114	892	11.26	10.20	5.00	6.31	8.50	0.63	2.49	4.88	0.19
1120	121,255	2700	2.38	5.00	167	1709	12.56	12.01	5.87	7.06	9.69	0.63	2.91	5.63	0.25
1130	176,129	2400	2.63	6.00	254	3691	14.88	12.99	6.37	8.56	11.18	0.87	2.97	5.79	0.25
1140	253,130	2200	2.63	7.25	381	6475	16.38	14.76	7.25	10.00	12.68	0.87	3.09	6.14	0.25

\* Coupling weight and WR<sup>2</sup> with no bore

\*\* Max bore is for hub with keyway for rectangular key