

Heavy Duty Spacer Coupling HSH Series - Form-Flex®

Double Flex Spacer

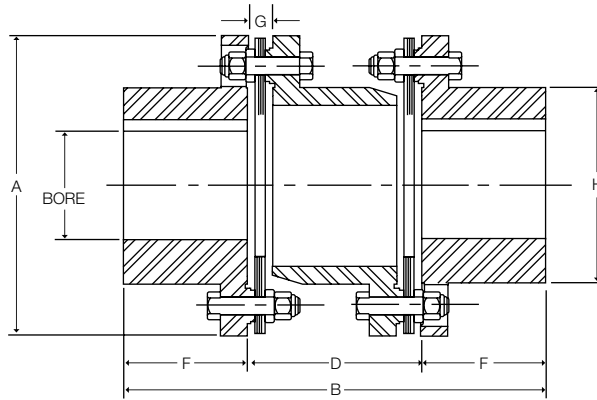

STANDARD MATERIALS

HUBS - CARBON STEEL
 SPACER - GREY OR DUCTILE IRON
 HARDWARE - ALLOY STEEL
 DISC PACKS - HIGH CARBON STEEL

MATERIAL / FINISH OPTIONS

DISC PACKS - STAINLESS STEEL
 ZINC PHOSPHATE COATING
 ALLOY STEEL HUBS
 CAST IRON HUBS
 (Sizes 31-45)

Size	Dimensions (in)									
	Max Bore				A (2)	B	D DBSE	F	G	H
	Iron		Steel							
(in)	(mm)	(in)	(mm)							
22	-	-	2.75	79	5.88	8.02	3.02	2.50	0.43	3.87
26	-	-	3.25	92	6.88	9.25	3.50	2.88	0.55	4.50
31	3.12	82	4.13	113	8.12	10.87	4.12	3.37	0.62	5.50
35	3.62	97	4.50	125	9.12	12.06	4.57	3.75	0.66	6.12
37	3.75	100	4.63	130	10.06	13.12	5.14	4.00	0.81	6.50
42	4.25	114	5.00	142	11.00	13.93	5.43	4.25	0.81	7.00
45	4.50	120	5.50	150	11.87	14.75	5.75	4.50	0.87	7.43
50	-	-	6.13	170	12.90	16.81	6.81	5.00	1.06	8.37
55	-	-	6.88	193	15.00	18.68	7.68	5.50	1.25	9.50
60	-	-	7.50	212	16.00	20.93	8.43	6.25	1.34	10.50
70	-	-	8.50	233	18.50	23.62	9.56	7.00	1.50	11.75
75	-	-	9.00	261	20.00	25.00	10.50	7.25	1.53	13.00
80	-	-	9.12	275	22.00	26.87	11.37	7.75	1.56	13.75
85	-	-	10.38	290	23.75	28.62	12.12	8.25	1.62	14.50
92	-	-	11.00	320	25.75	31.00	13.01	9.00	1.75	15.87
92HT	-	-	10.50	307	25.75	31.00	13.01	9.00	1.75	15.87

Size	HP/ 100 RPM	Rated Torque (lb-in)	Peak O/L Torque (lb-in)	Max RPM	Weight (lbs) (1)	WR ² (lb-in ²) (1)	Misalignment Capacity	
							Axial (+/- in)	Angular (Degrees/ Discpack)
22	15.1	9,500	14,250	3,800	19.7	75.6	0.036	0.33°
26	25.4	16,000	24,000	3,300	28.8	152	0.044	
31	38.1	24,000	36,000	2,800	51.4	390	0.052	
35	69.8	44,000	66,000	2,600	76.7	738	0.056	
37	95.2	60,000	90,000	2,500	92.4	1,090	0.062	
42	116	73,000	109,500	2,400	125	1,710	0.067	
45	157	99,000	148,500	2,250	154	2,510	0.072	
50	203	128,000	192,000	2,000	218	4,570	0.082	
55	300	189,000	283,500	1,800	288	7,400	0.092	
60	414	261,000	391,500	1,600	403	13,100	0.102	
70	659	415,000	622,500	1,400	624	25,800	0.115	
75	846	533,000	799,500	1,300	788	37,900	0.125	
80	1,087	685,000	1,027,500	1,200	1,030	58,700	0.136	
85	1,316	829,000	1,243,500	1,100	1,230	79,000	0.140	
92	1,651	1,040,000	1,560,000	1,000	1,630	129,000	0.156	
92HT	2,221	1,400,000	2,100,000	1,000	1,680	137,000	0.156	

1) Weight and WR² are calculated with steel hubs at maximum inch bore size.

2) Consult factory for torsional stiffness and alternating torque limits.

ORDERING

HSH SERIES COUPLINGS ARE SOLD AS COMPLETE ASSEMBLIES (Components and repair kits are available for repairs)

- 1) Specify coupling
- 2) Specify hub bore size and tolerance, keyway size or specify for each hub.
- 3) Specify disc pack material