

Spacer Coupling AP Series - Form-Flex®

Double Flex Spacer

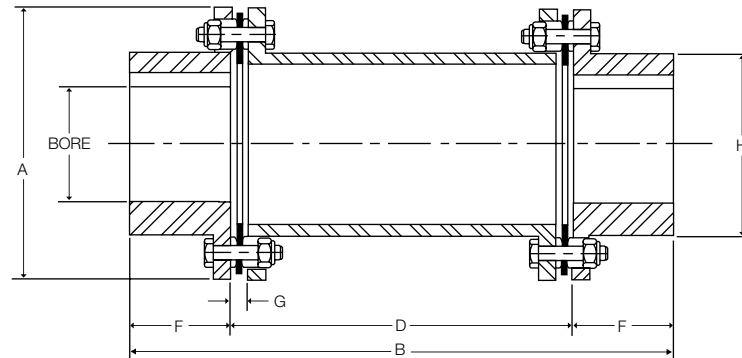

COUPLING CAN BE SUPPLIED TO API610 11TH EDITION

Size	Max Bore				Dimensions (mm)								
	AJ		AZ		A	B		D DBSE		F	G	H	J
	(mm)	(in)	(mm)	(in)		Min	Max	Min	Max				
5	22	0.875	30	1.19	67.3	94.5	176.2	43.7	125.4	25.4	6.1	33.0	13.7
10	33	1.250	43	1.63	81.0	103.1	177.8	52.3	127.0	25.4	6.9	45.7	14.2
15	36	1.375	48	1.75	92.7	118.6	225.7	61.2	168.3	28.7	8.1	50.8	22.4
20	46	1.688	58	2.13	103.6	127.5	235.3	60.5	168.3	33.5	8.6	61.0	20.1
25	53	2.000	68	2.56	125.7	156.5	333.1	74.2	250.8	41.1	11.4	71.1	25.4
30	63	2.380	79	2.88	143.0	192.3	347.9	96.8	252.4	47.8	11.9	83.8	29.0
35	80	2.938	101	3.75	168.4	223.8	446.1	109.5	331.8	57.2	14.0	105.4	24.6

Dimensions are shown for standard AJ hubs unless otherwise specified.

Size	kW/100 RPM	Rated Torque (Nm)	Peak O/L Torque (Nm)	AGMA 7 Max RPM	Weight (kg) (1)		WR ² (kg-cm ²) (1)		Misalignment Capacity	
					at D Min	Add Per cm of D	at D Min	Add Per cm of D	Axial (+/-mm)	Angular (Degrees/Disc Pack)
5	0.36	34	68	8,500	1.05	0.025	5.47	0.058	0.076	1°
10	0.95	90	181	7,500	1.65	0.039	13.11	0.127	1.01	
15	1.87	178	356	6,700	2.47	0.047	25.93	0.219	1.06	
20	2.60	249	497	6,200	3.16	0.057	40.38	0.392	1.39	
25	4.50	429	859	5,500	5.77	0.073	113.5	0.714	1.52	
30	8.21	783	1566	5,000	8.64	0.082	227.4	1.060	1.65	
35	13.4	1281	2562	4,400	12.55	0.113	456.5	2.638	2.16	

1) Weight and WR² values shown are for AJ hubs at max inch bore and spacer length at D Min

STANDARD MATERIALS (CLASS A)

HUBS - CARBON STEEL

SPACER - CARBON STEEL

HARDWARE - ALLOY STEEL

DISC PACK - STAINLESS STEEL

ORDERING

AP SERIES COUPLINGS ARE SOLD AS COMPONENTS

COUPLINGS CONSIST OF:

2 - HUBS - Example (AJ25A x 45 mm)

1 - SPACER SUB-ASSEMBLY - Example for DBSE = 120 mm (AP25A120MM)

MATERIAL / FINISH OPTIONS

CLASS A - Steel hubs and spacer, alloy steel hardware, 300 series stainless steel disc pack

CLASS B - Zinc plated steel hubs, and spacer, alloy steel hardware, 300 series stainless steel disc pack

CLASS C - Zinc plated steel hubs, and spacer, stainless steel hardware, 300 series stainless steel disc pack

CLASS E - 300 series stainless steel hubs and spacer, stainless steel hardware, 300 series stainless steel disc pack

(Only available for sizes 15 thru 35)