

Dura-Flex® BTS Couplings

Dimensions

Assembly Dimensions for BTS Couplings.

(All dimensions in inches) Minimum Shaft Spacing = .25"

Dimensions Common to BTS Standard and Spacer Assemblies

SIZE	A	B	C	Max. Bore
WE2 & WES2	3.70	1.85	0.94	1-1/8
WE3 & WES3	4.24	2.32	1.50	1-3/8
WE4 & WES4	4.52	2.60	1.69	1-11/16
WE5 & WES5	5.40	3.13	1.75	1-7/8
WE10 & WES10	6.48	3.65	1.88	2-1/8
WE20 & WES20	7.36	4.48	2.06	2-3/8
WE30 & WES30	8.41	5.42	2.31	2-7/8
WE40 & WES40	9.71	6.63	2.50	3-3/8
WE50 & WES50	11.34	8.13	2.75	3-5/8
WE60 & WES60	12.53	8.75	3.25	4
WE70 & WES70	14.00	9.25	3.62	4-1/2
WE80 & WES80	16.00	11.30	4.98	6

Standard Element Assembly

Product No.*	OAL MAX	OAL MIN	Maximum DBSE	Weight lbs.
WE2	3.78	3.22	1.90	1.5
WE3	4.32	3.80	1.32	3.3
WE4	4.68	3.82	1.30	4.4
WE5	5.30	4.32	1.80	7.4
WE10	5.57	4.33	1.81	11.2
WE20	6.82	4.62	2.70	16.3
WE30	7.61	5.19	2.99	27.7
WE40	8.16	5.56	3.16	45.4
WE50	9.21	6.13	3.71	59.0
WE60	10.70	7.20	4.20	82.6
WE70	11.88	8.24	4.64	109
WE80	16.60	10.48	6.64	242

* Product number is element only.

Spacer Element Assembly

Product No.*	OAL MAX	OAL MIN	Maximum DBSE	Weight lbs.
WES2	5.92	5.72	4.04	2.5
WES3	8.02	7.50	5.02	4.8
WES4	8.38	7.52	5.00	6.1
WES5	8.50	7.52	5.00	9.4
WES10	8.76	7.52	5.00	13.6
WES20	11.17	9.35	7.05	19.2
WES30	11.65	9.35	7.03	31.0
WES40	11.89	9.35	6.89	48.9
WES50	12.31	9.35	6.81	63.5
WES60	16.28	12.78	9.78	91.0
WES70	16.81	13.17	9.57	128
WES80	19.73	13.61	9.77	258

* Product number is element only.

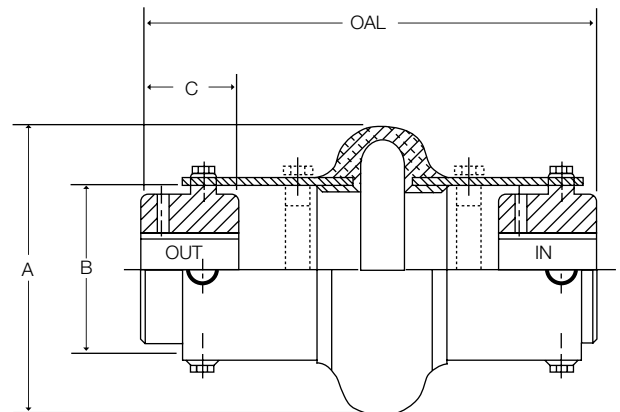
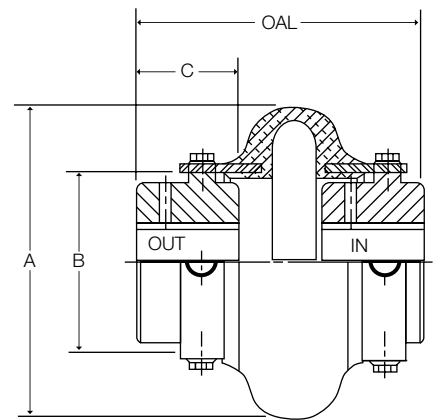

Sizes WES2 through WES10 are furnished with high speed rings. All larger sizes, rings can be ordered as an option.

All weights shown are with MPB style hubs.

Shaft Spacing from 1/4" up to the MAX DBSE can be accommodated by positioning hubs IN or OUT or by using various existing hole patterns.
OAL - Over All Length does not include bolt heads