

SYNTEX®

Backlash-free overload systems

With sprocket



For legend of pictogram please refer to flapper on the cover



Technical data – Dimensions

Size	Torque [Nm]				Max. speed [rpm] ²⁾	Dimensions [mm]																
	Ratchet design DK		Synchronous design SK			Max. bore		Standard sprocket ¹⁾														
	DK1	DK2	SK1	SK2		d	D	D ₁	D ₂	l ₁	l ₃	l ₅	L	H=stroke								
20	6-20	15-30	10-20	20-65	1500	20	06B-1 (⁹ / ₈ x ⁷ / ₃₂) z = 25								48	54	61,5	8	14	33	45	2
25	20-60	45-90	25-65	40-100	1500	25	08B-1 (¹ / ₂ x ⁵ / ₁₆) z = 24								60	68	80	8	15	37	50	2
35	25-80	75-150	30-100	70-180	1000	35	08B-1 (¹ / ₂ x ⁵ / ₁₆) z = 29								75	78	91	10	19	41	60	2
50	60-180	175-300	80-280	160-400	1000	50	12B-1 (⁹ / ₄ x ⁷ / ₁₆) z = 27								105	108	121	12	23	52	70	2

Dimensions of hub type 4.5

Size	Dimensions [mm]							Tightening torque T _A [Nm]
	d _{1max.}	l ₆	l ₇	l ₈	L ₁	s	Clamping screws	
20	20	9	3,5	23	54	3	4 x M5	8,5
25	25	11	4,0	28	61	4	4 x M6	14
35	35	10	4,0	31	70	4	4 x M6	14
50	50	12	4,0	37	82	6	4 x M6	14

Transmittable friction torques T_R [Nm] (fitting tolerance H7/h6) of hub type 4.5

Size	Ø12	Ø14	Ø15	Ø16	Ø17	Ø18	Ø19	Ø20	Ø22	Ø23	Ø24	Ø25	Ø28	Ø30	Ø32	Ø35	Ø38	Ø40	Ø42	Ø45	Ø48	Ø50
20	45	62	71	81	92	103	115	127														
25		72	83	95	107	120	133	148	179	196	213	231										
35									127	139	152	165	207	237	270	323						
50																238	281	311	343	394	448	486

¹⁾ z = minimum number of teeth required / other sprockets available on request

²⁾ See comments on page 230

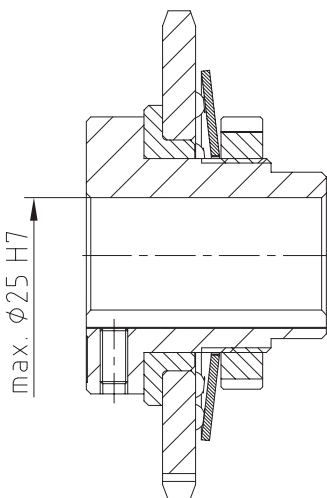

Special type

- Standard SYNTEX® with integrated belt drive
- Available ready for assembly with the torque set
- Reduction of number of components by integration of components
- Available both as a ratchet and synchronous design
- Torque setting possible while in place
- Finish bore according to ISO fit H7, feather keyway according to DIN 6885 sheet 1 - JS9
- Also available with a frictionally engaged shaft-hub-connection (hub design 4.5)

Ordering example:

SYNTEX® 25	DK1	1.0	d Ø20	08B-1 (¹ / ₂ x ⁵ / ₁₆), z=29	45 Nm
Type / size	Type [DK/SK]	Hub type	Bore	Sprocket	Torque set