

# RUFLEX® Torque limiters

With torsionally flexible ROTEX®

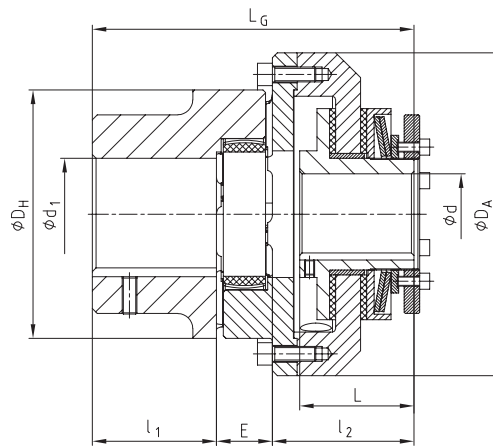

For legend of pictogram please refer to flapper on the cover



### Technical data – Dimensions

RUFLEX® size	ROTEX® size	RUFLEX® torques [Nm]			ROTEX® torques [Nm] <sup>3)</sup>		Dimensions [mm]									
		1TF	2TF	3TF <sup>2)</sup>	98 Shore-A		Bore d		Max. bore d <sub>1</sub>	D <sub>H</sub>	D <sub>A</sub>	l <sub>1</sub>	l <sub>2</sub>	E	L	L <sub>G</sub>
					T <sub>KN</sub>	T <sub>Kmax</sub>	pilot b.	max.								
00	14	0,5-3	1-5	-	12,5	25	-	10	16	30	44	11	35	13	31	59
0	19	2-10	4-20	-	17	34	-	20 <sup>1)</sup>	25	40	63	25	37	16	33	78
01	24	5-35	10-70	-	60	120	-	22	35	55	80	30	50	18	45	98
1	28	20-75	40-150	130-200	160	320	-	25	40	65	98	35	58	20	52	113
2	38	25-140	50-280	250-400	325	650	-	35	48	80	120	45	64	24	57	133
3	48	50-300	100-600	550-800	525	1050	-	45	62	105	162	56	82	28	68	166
4	75	90-600	180-1200	1100-1600	1920	3840	-	55	95	160	185	85	80	40	78	205
5	90	400-800	800-1600	1400-2100	3600	7200	-	65	110	200	260	100	114	45	92	259
6	100	300-1200	600-2400	-	4950	9900	38	80	115	225	285	110	130	50	102	290
7	110	600-2200	1200-4400	-	7200	14400	45	100	125	255	330	120	142	55	113	317
8	140	900-3400	1800-6800	-	12800	25600	58	120	160	372	410	115	65	155	152	372

<sup>1)</sup> Finish bore exceeding Ø19, feather keyway acc. to DIN 6885 sheet 3

<sup>2)</sup> With clamping setting nut, to use only for designs with limited dimensions

<sup>3)</sup> See selection of ROTEX couplings on page 10 et seqq.

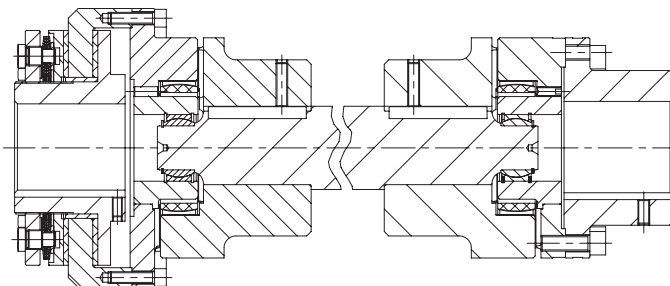

### Special type:

- RUFLEX® as intermediate shaft coupling
- For large shaft distance dimensions
- Available in combination with ROTEX® or RADEX®-N steel lamina coupling

### Ordering example:

RUFLEX® 1	2TF	d Ø20	ROTEX® 28	98 Sh-A	d <sub>1</sub> Ø25	100 Nm
Type/size	Disk spring layer	RUFLEX® bore	Type/size	Spider	ROTEX® bore	Torque set