

# Drop-out center design coupling

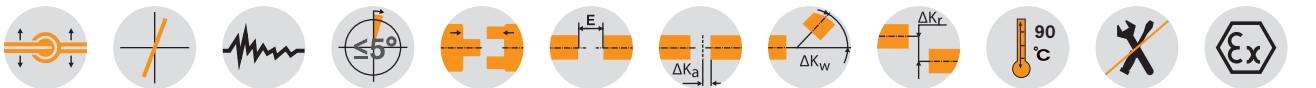

Type A-H

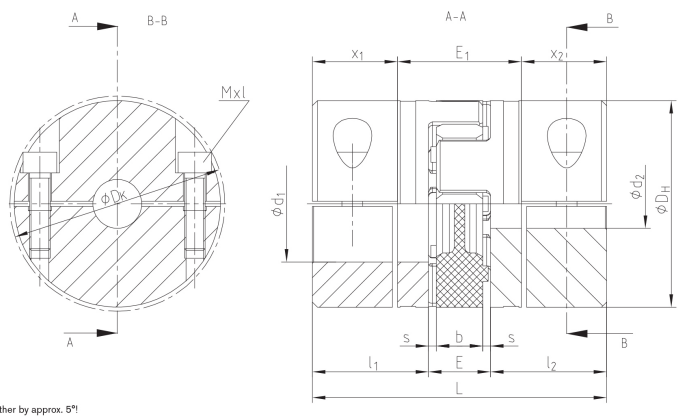

Please note:  
The feather keys are offset to each other by approx. 5°  
Hub material: Al-H

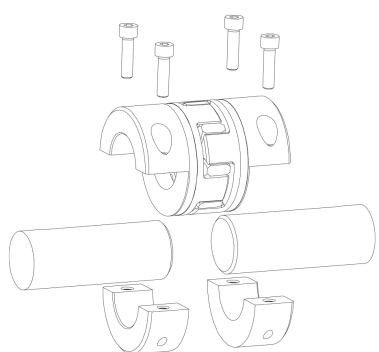

Type 7.8

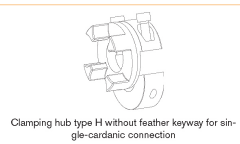

Type 7.9

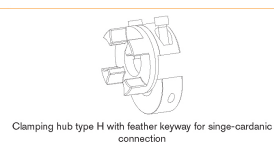

## ROTEX® GS Type A-H hub material aluminium

Size	Max. finish bore Ød [mm]	Dimensions [mm]										Cyl. screws DIN EN ISO 4762	
		L	l <sub>1</sub> ; l <sub>2</sub>	E	b	s	D <sub>H</sub>	D <sub>K</sub>	x <sub>1</sub> /x <sub>2</sub>	E <sub>1</sub>	Mxl	T <sub>A</sub> [Nm]	
19	20	66	25	16	12	2,0	40	46	17,5	31	M6x16	10	
24	28	78	30	18	14	2,0	55	57,5	22,0	34	M6x20	10	
28	38	90	35	20	15	2,5	65	73	25,0	40	M8x25	25	
38	45	114	45	24	18	3,0	80	83,5	33,0	48	M8x30	25	
42	50	126	50	26	20	3,0	95	93,5	39	48	M10x30	49	

## Technical data

Size	Spider Shore-GS <sup>1)</sup>	Shore range	Max. speed [rpm]	Torque [Nm]		Static torsion spring stiffness <sup>2)</sup> [Nm/rad]	Weight per hub with max. bore [kg]	Mass moment of inertia J of each hub with max. bore diameter [kgm <sup>2</sup> ]
				T <sub>KN</sub>	T <sub>Kmax</sub>			
19	80	A	9550	6,0	12,0	618	77 x 10 <sup>-3</sup>	19,6 x 10 <sup>-6</sup>
	92	A		12,0	24,0	1090		
	98	A		21,0	42,0	1512		
	64	D		26,0	52,0	2560		
24	92	A	6950	35	70	2280	161 x 10 <sup>-3</sup>	77,3 x 10 <sup>-6</sup>
	98	A		60	120	3640		
	64	D		75	150	5030		
28	92	A	5850	95	190	4080	240 x 10 <sup>-3</sup>	173 x 10 <sup>-6</sup>
	98	A		160	320	6410		
	64	D		200	400	10260		
38	92	A	4750	190	380	6525	470 x 10 <sup>-3</sup>	496 x 10 <sup>-6</sup>
	98	A		325	650	11800		
	64	D		405	810	26300		
42	92	A	4000	265	530	10870	1770 x 10 <sup>-3</sup>	2409 x 10 <sup>-6</sup>
	98	A		450	900	21594		
	64	D		560	1120	36860		

<sup>1)</sup> Other spiders/selection see page 18 et seqq.

<sup>2)</sup> Static torsion spring stiffness with 0.5 x T<sub>KN</sub>

To make sure that the coupling can be assembled/disassembled radially, please observe the insertion dimension x<sub>1</sub>/x<sub>2</sub> of the shafts.

## Review of shaft-hub-connection: Friction torques for hub type 7.8

Size	Ø8	Ø10	Ø11	Ø14	Ø15	Ø16	Ø18	Ø19	Ø20	Ø22	Ø24	Ø25	Ø28	Ø30	Ø32	Ø35	Ø38	Ø40	Ø42	Ø45	Ø46	Ø48	Ø50
19	17	21	23	30	32	34	38	40	42														
24		21	23	30	32	34	38	40	42	47	51	53	59										
28				54	58	62	70	74	78	86	93	97	109	117	124	136	148						
38							70	74	78	86	93	97	109	117	124	136	148	156	163	175			
42										136	149	155	174	186	198	217	235	248	260	279	285	297	310

## Ordering example:

ROTEX® GS 38	A-H	98 Sh-A-GS	7.8 – Ø 38	7.9 – Ø 30
Coupling size	Type	Spider hardness	Hub type	Finish bore
			Hub type	Finish bore