

Flange programme

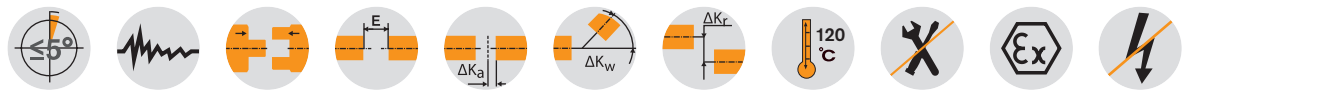

Components

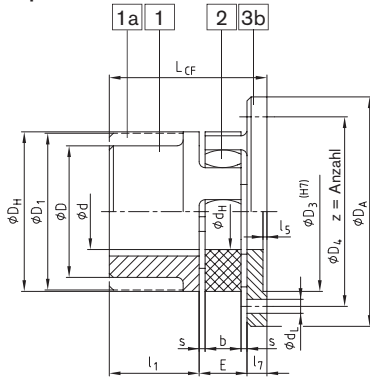

Type CF

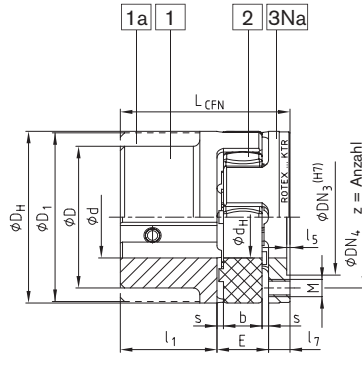

Type CFN

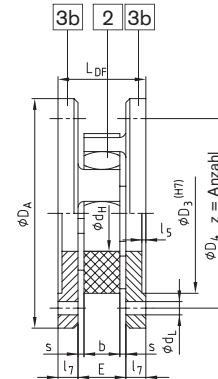

Type DF

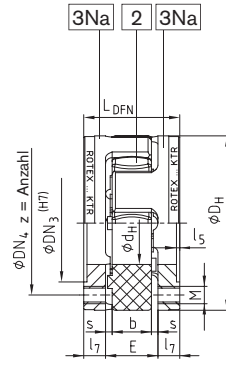

Type DFN

ROTEX® Type CF, CFN (No. 005) and DF, DFN (No. 006)

Size	d, φD, φD1	General dimension							Dimensions CF and DF							Dimensions CFN and DFN							
		DH	dH	l1	E	s	b	l5	l7	DA	D3	D4	z	dL	LCF	LDF	DN3	DN4	M	z	Pitch	LCFN	LDFN
24	See shaft coupling on page 34 to 36 Stock programme/basic programme on page 32 and 33	55	27	30	18	2,0	14	1,5	8	80	55	65	5	4,5	56	34	36	45	M5	8	8x45°	56	34
28		65	30	35	20	2,5	15	1,5	10	100	65	80	6	6,6	65	40	44	54	M6	8		65	40
38		80	38	45	24	3,0	18	1,5	10	115	80	95	6	6,6	79	44	54	66	M8	8		79	44
42		95	46	50	26	3,0	20	2,0	12	140	95	115	6	9,0	88	50	65	80	M8	12	16x22,5°	88	50
48		105	51	56	28	3,5	21	2,0	12	150	105	125	8	9,0	96	52	75	90	M8	12		96	52
55		120	60	65	30	4,0	22	2,0	16	175	120	145	8	11,0	111	62	84	102	M10	8		8x45°	111
65		135	68	75	35	4,5	26	2,0	16	190	135	160	10	11,0	126	67	96	116	M10	12	16x22,5°	126	67
75		160	80	85	40	5,0	30	2,5	19	215	160	185	10	13,5	144	78	112	136	M12	15		144	78
90		200	100	100	45	5,5	34	3,0	20	260	200	225	12	13,5	165	85	145	172	M16	15		165	85
100		225	113	110	50	6,0	38	4,0	25	285	225	250	12	13,5	185	100	165	195	M16	15		185	100
110		255	127	120	55	6,5	42	4,0	26	330	255	290	12	18,0	201	107	180	218	M20	15	20x18°	201	107
125		290	147	140	60	7,0	46	5,0	30	370	290	325	16	18,0	230	120	215	252	M20	15		230	120
140		320	165	155	65	7,5	50	5,0	34	410	320	360	16	22,0	254	133	245	282	M20	15		254	133
160		370	190	175	75	9,0	57	5,0	38	460	370	410	16	22,0	288	151	280	325	M24	15		288	151
180		420	220	195	85	10,5	64	5,5	40	520	420	465	16	26,0	320	165	330	375	M24	18	24x15°	320	165

For other flange programmes see page 43.

Other types: ROTEX® CF-H

Flange drop-out center design coupling

Please order our separate dimension sheet (M412069)

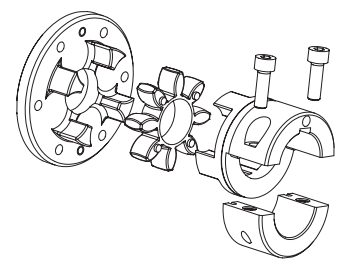

Ordering example:

ROTEX® 38	CF	92 Sh-A	1	GJL	Ø20
Coupling size	Type	Spider hardness	Hub side Component	Material	Finish bore