

Flange programme

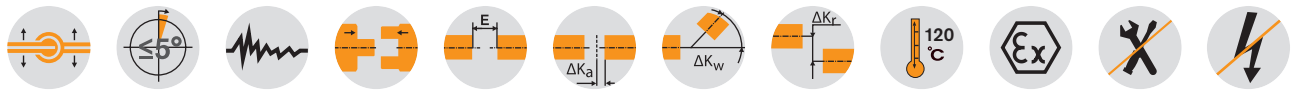

Components

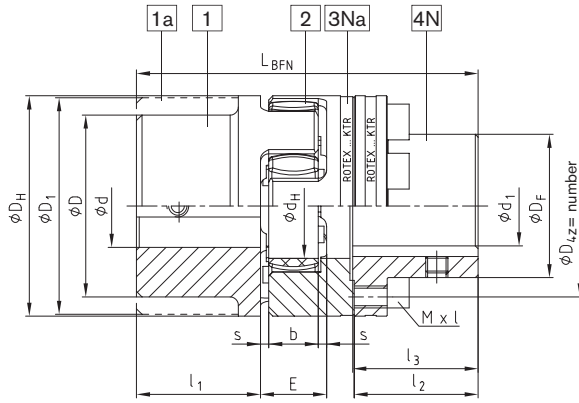

Type BFN

ROTEX® Type AFN (No. 002) and BFN (No. 004)

Size	Pilot bored Ød; ØD; ØD1	Component 4N max. finish bore Ød1	Dimensions [mm]													Cap screws 3) DIN EN ISO 4762 - 12.9			
			DH	DF	D4	dH	l ₁ ; l ₂	E	E ₁	s	b	l ₃ ; l ₄	L _{AFN}	L _{BFN}	Mxl	z	Pitch 2)	¹⁾ T _A [Nm]	
24	See jaw couplings on page 34 to 39 Stock programme/basic programme on page 32 and 33	24	55	36	45	27	30	18	33	2,0	14	30,5	94	86	M5x16	8		10	
28		28	65	42	54	30	35	20	39	2,5	15	35,5	110	100	M6x20	8	8x45°	17	
38		38	80	52	66	38	45	24	43	3,0	18	45,5	134	124	M8x22	8		41	
42		42	95	62	80	46	50	26	48	3,0	20	51,0	150	138	M8x25	12		41	
48		48	105	70	90	51	56	28	50	3,5	21	57,0	164	152	M8x25	12	16x22,5°	41	
55		55	120	80	102	60	65	30	60	4,0	22	66,0	192	176	M10x30	8	8x45°	83	
65		65	135	94	116	68	75	35	65	4,5	26	76,0	217	201	M10x30	12	16x22,5°	83	
75		75	160	108	136	80	85	40	75	5,0	30	86,5	248	229	M12x40	15		120	
90		100	200	142	172	100	100	45	82	5,5	34	101,5	285	265	M16x40	15		295	
100		110	225	158	195	113	110	50	97	6,0	38	111,5	320	295	M16x50	15		295	
110		125	255	178	218	127	120	55	103	6,5	42	122,0	347	321	M20x50	15	20x18°	580	
125		145	290	206	252	147	140	60	116	7,0	46	142,0	400	370	M20x60	15		580	
140		165	320	235	282	165	155	65	128	7,5	50	157,5	443	409	M20x60	15		580	
160		190	370	270	325	190	175	75	146	9,0	57	177,5	501	463	M24x70	15		1000	
180		220	420	315	375	220	195	85	159	10,5	64	198,0	555	515	M24x80	18	24x15°	1000	

- ¹⁾ Screw tightening torque T_A [Nm].
- ²⁾ Thread in driving flange between cams.
- ³⁾ Coupling is delivered not assembled.

Ordering example:	ROTEX® 24	AFN	92 Sh-A	4N	Ø 38	4N	Ø35
		Coupling size	Type	Spider hardness	Component	Finish bore	Component