

Double- and single-cardanic types

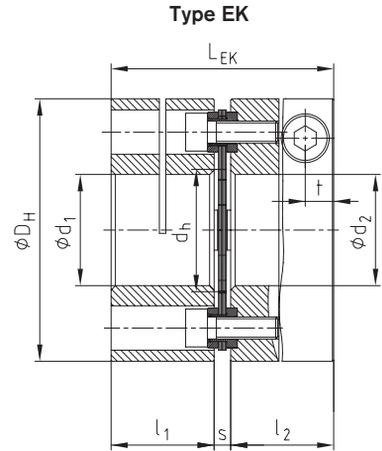
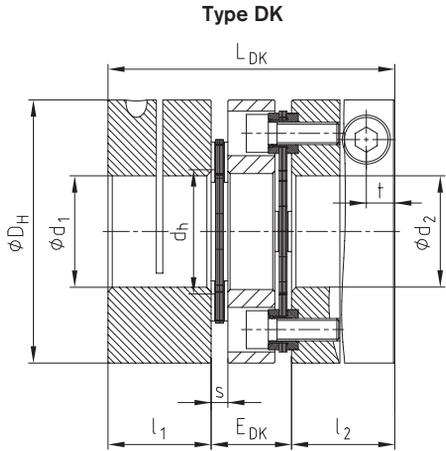
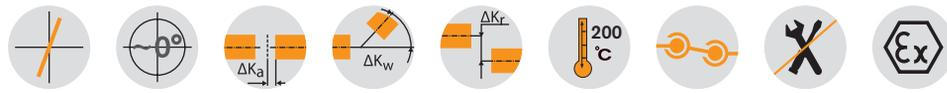

RADEX®-NC Types DK and EK Hub and spacer material aluminium (size 42 steel)/laminas stainless steel

Size	Dimensions [mm]									Clamping screw		Mass moments of inertia	
	max. d1/d2	DH	l1:l2	LDK	EDK	LEK	dh	s	t	M	TA [Nm]	DK [kgm²]	EK [kgm²]
5	12	26	12	34	10	26,5	12	2,5	3,5	M2,5	0,8	0,000004	0,000003
10	15	35	16	44	12	35	14,5	3	5,0	M4	3	0,000016	0,000012
15	20	47	21	55	13	45	19,5	3	6,8	M6	10	0,000065	0,000053
20	25	59	24	67	19	52	24	4	6,5	M6	10	0,000199	0,000154
25	35	70	32	88	24	69	30	5	9,0	M8	25	0,000508	0,000393
35	42	84	35	98	28	77	38	7	10,5	M10	49	0,001153	0,000911
42	55	104	40	116	36	91	48	11	10,5	M10	69	0,007458	0,006153

Technical data

Size	TKN ¹⁾ [Nm]	TK max ¹⁾ [Nm]	Max. speed [rpm]	Torsion spring stiffness [Nm/rad]		Displacement type DK			Displacement type EK		
				Type EK	Type DK	Radial [mm]	Axial [mm]	Angular [°]	Radial [mm]	Axial [mm]	Angular [°]
5	2,5	5	25000	2400	1200	0,10	0,4	1	—	0,2	1
10	7,5	15	20000	5600	2800	0,14	0,8	1	—	0,4	1
15	20	40	16000	12000	6000	0,16	1,0	1	—	0,5	1
20	30	60	12000	30000	15000	0,25	1,2	1	—	0,6	1
25	60	120	10000	60000	30000	0,30	1,6	1	—	0,8	1
35	100	200	9000	72000	36000	0,40	2,0	1	—	1,0	1
42	300	600	7000	240000	120000	0,50	2,8	1	—	1,4	1

¹⁾ See page 18 et seqq.

Review of shaft-hub-connection: Friction torques for hub type 2.5

Size	Pilot bored	Ø3	Ø5	Ø8	Ø10	Ø12	Ø14	Ø15	Ø16	Ø19	Ø20	Ø24	Ø25	Ø28	Ø30	Ø32	Ø35	Ø38	Ø40	Ø45	Ø50	Ø55
5	2,5	2,2	2,3	2,4	2,5																	
10	4,5		8	9	10	10	11	11														
15	5,5				28	30	31	32	32	34	35											
20	7,5					36	37	38	39	40	41	44	45									
25	9,5							82	83	87	88	93	94	98	100	103	106					
35	11,5									155	157	165	167	173	177	181	187	193	197			
42	15,0											285	287	296	301	307	315	323	329	343	357	370

Ordering-example:

RADEX®-NC 20	DK	2.5	Ø20	2.5	Ø25
Coupling size	Type	Hub type	Finish bore	Hub type	Finish bore