

KTR Precision joints type X and XD

According to DIN 808 with plain bearing made of stainless steel



For legend of pictogram please refer to flapper on the cover



Precision single joint X

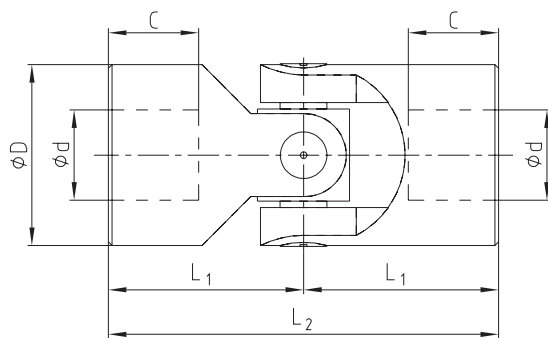

Precision double joint XD

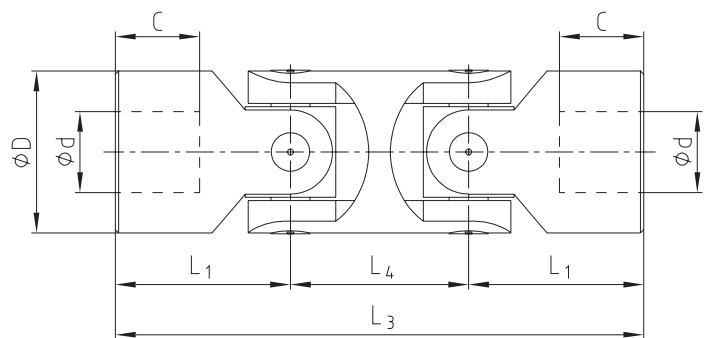

Finish bores:

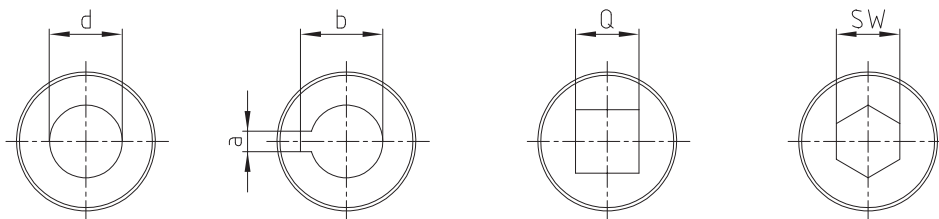

Type X and XD																
Types and size				Dimensions [mm]											Weight [kg]	
Size X	DIN description X	Size XD	DIN description XD	d [H7]	D	L ₂	L ₁	C	L ₄	L ₃	a [JS9]	b	Q [H10]	SW [H8]	X	XD
01 X	E6 x 16-G	01 XD	D6 x 16-G	6	16	34	17	8	22	56	2	7,0	6	6	0,05	0,08
02 X	E8 x 16-G	02 XD	D8 x 16-G	8	16	40	20	11	22	62	2	9,0	8	8	0,05	0,08
03 X	E10 x 22-G	03 XD	D10 x 22-G	10	22	48	24	12	26	74	3	11,4	10	10	0,10	0,15
04 X	E12 x 25-G	04 XD	D12 x 25-G	12	25	56	28	13	30	86	4	13,8	12	12	0,16	0,25
1 X	E16 x 32-G	1 XD	D16 x 32-G	16	32	68	34	16	37	105	5	18,3	16	16	0,30	0,45
3 X	E20 x 42-G	3 XD	D20 x 42-G	20	42	82	41	18	47	129	6	22,8	20	20	0,60	1,00
5 X	E25 x 50-G	5 XD	D25 x 50-G	25	50	108	54	26	55	163	8	28,3	25	25	1,20	2,00
6 X	E30 x 58-G	6 XD	D30 x 58-G	30	58	122	61	29	68	190	8	33,3	30	30	1,85	2,90

Ordering example:	04 X	Ø12	Ø12 Nute DIN
	Size/type of joint	Finish bore (H7)	Finish bore (H7) feather keyway acc. to DIN 6885 sheet 1 (JS9)