

Two-part

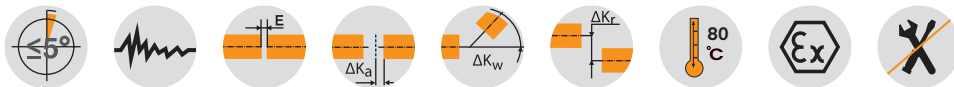

Components

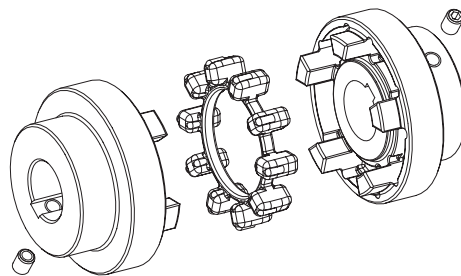
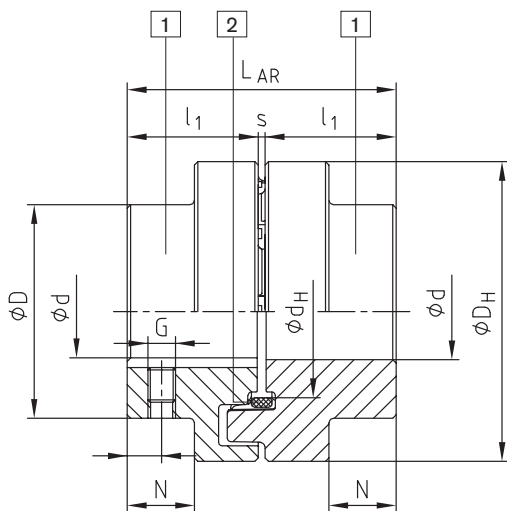

Size 28-125

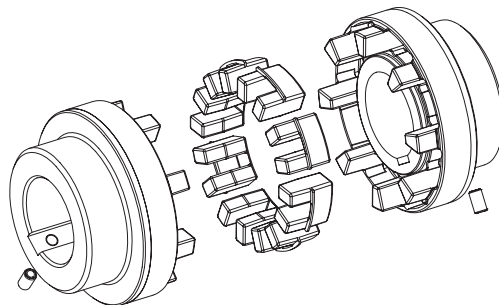

Size 140-280

Components of type AR 1 = standard hub (GJL) 2 = elastomer ring (up to size 180: NBR 78 Sh-A; from size 200: T-PUR® 84 Sh-A)

POLY-NORM® Type AR

Size	Elastomer ring (part 2) ¹⁾		Max. finish bore Ød ²⁾	Dimensions [mm]									Mass moment of inertia [kgm ²] ³⁾	AR ³⁾ weight [kg]
	torque [Nm]			General						Thread for setscrews				
	T _{KN}	T _{Kmax.}		LAR	l ₁	s	D _H	D	d _H	N	G	t		
28	40	80	30	59	28	3	69	46	36,5	12	M5	7	0,0004	0,9
32	60	120	35	68	32	4	78	53	41,5	14	M8	7	0,0008	1,4
38	90	180	40	80	38	4	87	62	50	19,5	M8	10	0,0016	2,0
42	150	300	45	88	42	4	96	69	55,5	20	M8	10	0,0026	2,7
48	220	440	50	101	48	5	106	78	64	24	M8	15	0,0042	3,7
55	300	600	60	115	55	5	118	90	73	29	M8	14	0,0070	5,5
60	410	820	65	125	60	5	129	97	81	33	M8	15	0,0112	6,9
65	550	1100	70	135	65	5	140	105	86	36	M10	20	0,0174	8,8
75	850	1700	80	155	75	5	158	123	100	42,5	M10	20	0,028	13,5
85	1350	2700	90	175	85	5	182	139	116	48,5	M10	25	0,052	19,5
90	2000	4000	95	185	90	5	200	148	128	49	M12	25	0,090	23,2
100	2900	5800	110	206	100	6	224	165	143	55	M12	25	0,160	31,9
110	3900	7800	50-120	226	110	6	250	185	158	60	M16	30	0,317	38,0
125	5500	11000	55-140	256	125	6	280	210	178	70	M16	35	0,570	55,2
140	7200	14400	65-155	286	140	6	315	235	216	76,5	M20	35	1,030	92,6
160	10000	20000	75-175	326	160	6	350	265	246	94,5	M20	45	1,746	126,9
180	13400	26800	75-200	366	180	6	400	300	290	111,5	M20	50	3,239	181,8
200	19000	38000	85-200	408	200	8	450	335	-	126	M24	50	5,728	263,7
220	30000	60000	95-220	448	220	8	500	370	-	140	M24	50	9,489	355,9
240	43000	86000	105-240	488	240	8	550	405	-	154	M24	50	14,963	466,3
260	55000	110000	115-260	530	260	10	650	440	-	158	M24	60	29,504	672,2
280	67000	134000	125-280	570	280	10	700	475	-	172	M24	60	42,451	836,6

¹⁾ Standard material Perbunan (NBR) 78 Shore-A, size 140-280 double tooth elastomers. For selection see page 10 et seqq.

²⁾ Bores H7 with keyway to DIN 6885 sheet 1 [JS9] and thread for setscrews on the feather keyway

³⁾ Referring to average bore