

CLAMPEX® KTR 400

Clamping elements

Self-centering clamping element with the highest transmission performance

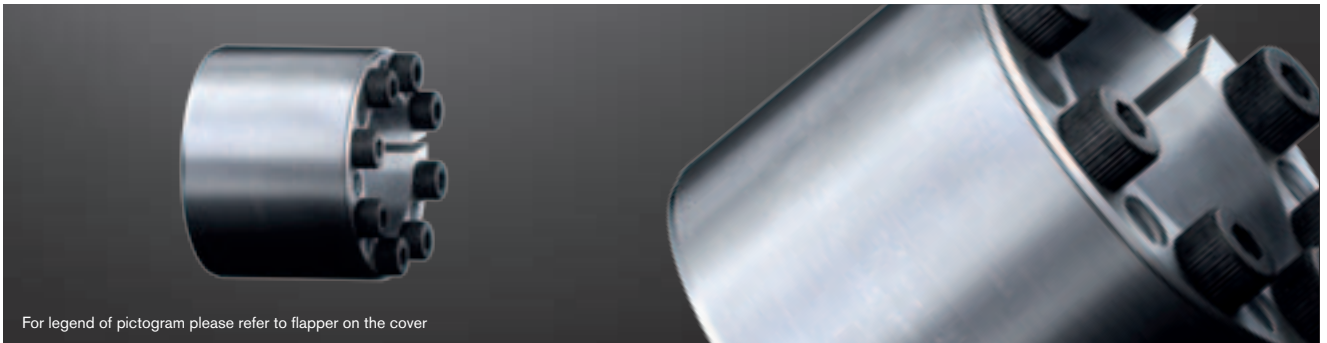

For legend of pictogram please refer to flapper on the cover

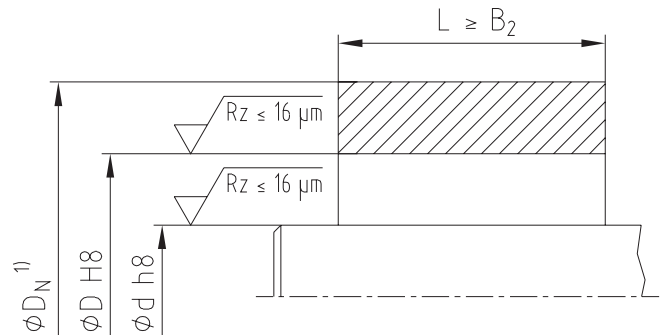
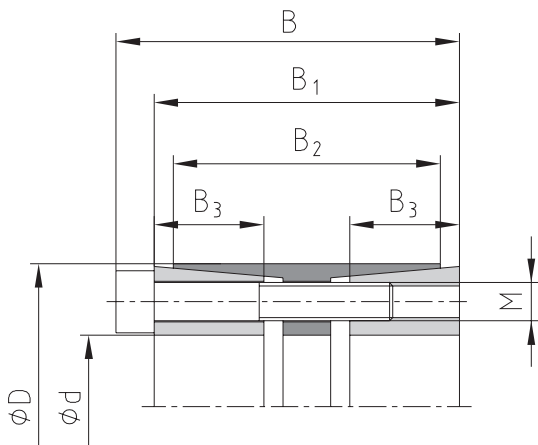
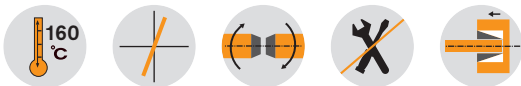

¹⁾ Dimension D_N : For calculation see page 263/264.

Example of application of hub type

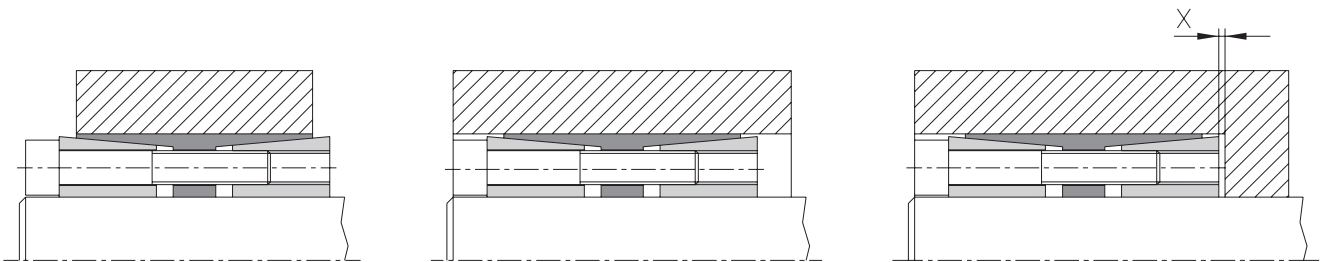

Formula to calculate space x left for disassembly:

$$x = \frac{B_1 - B_2}{2}$$

Ordering example:

KTR 400	100	x	145
Series	Size of inside diameter d		Size of outside diameter D

