

CLAMPEX® KTR 200 und KTR 201

Clamping elements

Self-centering clamping elements with a wide range of applications

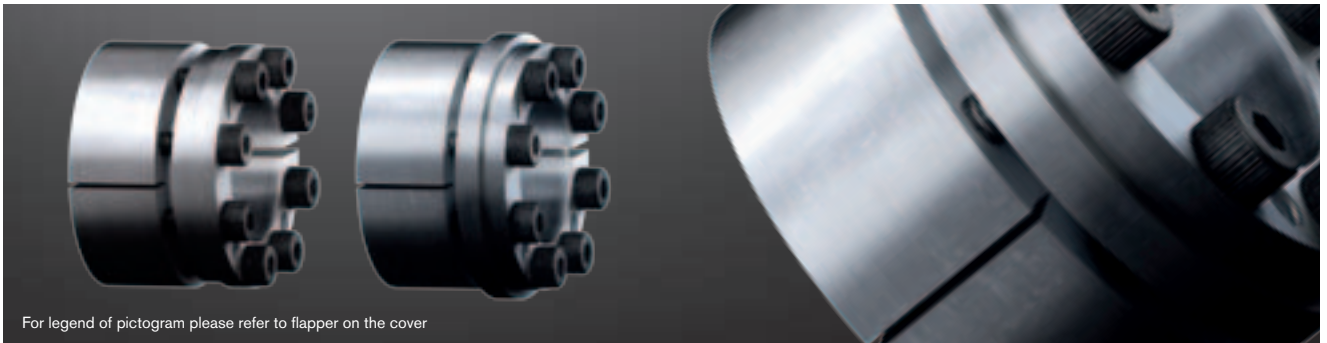

For legend of pictogram please refer to flapper on the cover

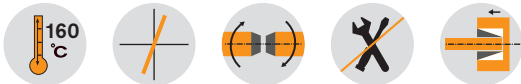

KTR 200

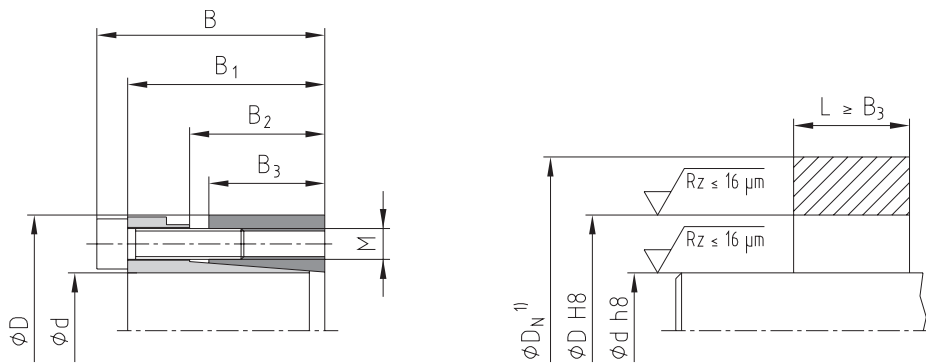

¹⁾ Dimension D_N : For calculation see page 263/264.

Example of application of hub type

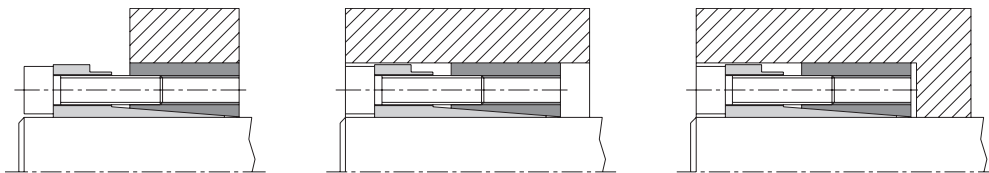

KTR 201

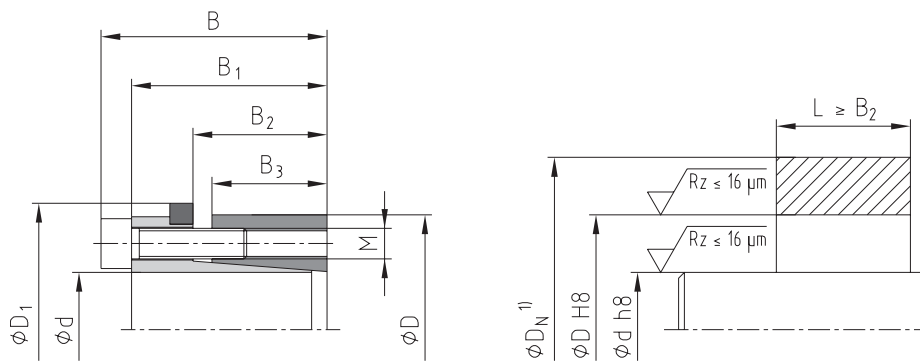

¹⁾ Dimension D_N : For calculation see page 263/264.

Example of application of hub type

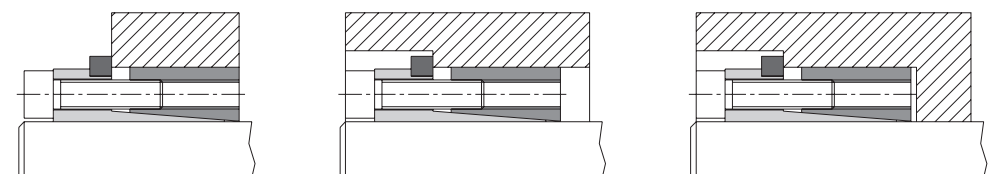

Ordering example:

KTR 200	40	x	65
Series	Size of inside diameter d		Size of outside diameter D

CLAMPEX® KTR 200 und KTR 201

Clamping elements

CLAMPEX® – KTR 200 und KTR 201

d x D [mm]	Dimensions [mm]					Clamping screws DIN EN ISO 4762 - 12.9 $\mu_{total}=0,14$				KTR 200				KTR 201								
						M	Length	z No. z	T _A [Nm] ¹⁾		T [Nm]	F _{ax} [kN]	Surface pressure between clamping element		T [Nm]	F _{ax} [kN]	Surface pressure between clamping element		Weight [-kg]	Stock programme		
	KTR 200	KTR 201	Shaft P _W [N/mm ²]	hub P _N [N/mm ²]	Shaft P _W [N/mm ²]				hub P _N [N/mm ²]													
20 x 47	48	42	31	26	53	M6	25	6	17	17	530	53	270	115	0,4	●	320	32	163	69	0,4	●
22 x 47	48	42	31	26	53	M6	25	6	17	17	580	53	245	114	0,4	●	360	33	152	71	0,4	●
24 x 50	48	42	31	26	56	M6	25	6	17	17	630	53	223	107	0,4	●	390	33	138	66	0,4	●
25 x 50	48	42	31	26	56	M6	25	6	17	17	660	53	215	108	0,4	●	400	32	131	65	0,4	●
28 x 55	48	42	31	26	61	M6	25	6	17	17	740	53	193	98	0,5	●	450	32	117	60	0,5	●
30 x 55	48	42	31	26	61	M6	25	6	17	17	790	53	179	98	0,5	●	490	33	111	61	0,5	●
32 x 60	48	42	31	26	66	M6	25	8	17	17	1150	72	229	122	0,6	●	690	43	137	73	0,6	●
35 x 60	48	42	31	26	66	M6	25	8	17	17	1300	74	217	126	0,6	●	750	43	125	73	0,5	●
38 x 65	48	42	31	26	71	M6	25	8	17	17	1300	68	184	107	0,6	●	820	43	116	68	0,6	●
40 x 65	48	42	31	26	71	M6	25	8	17	17	1400	70	179	110	0,6	●	860	43	110	67	0,6	●
42 x 75	59	51	35	30	81	M8	30	6	41	41	2000	95	200	112	1,0	●	1300	62	130	73	1,0	●
45 x 75	59	51	35	30	81	M8	30	6	41	41	2200	98	192	115	1,0	●	1400	62	122	73	1,0	●
48 x 80	59	51	35	30	86	M8	30	8	41	41	3200	133	246	147	1,1	●	1900	79	146	87	1,1	●
50 x 80	59	51	35	30	86	M8	30	8	41	41	3300	132	233	146	1,1	●	2000	80	141	88	1,1	●
55 x 85	59	51	35	30	91	M8	30	8	41	41	3600	131	210	136	1,2	●	2200	80	129	83	1,2	●
60 x 90	59	51	35	30	96	M8	30	8	41	41	3900	130	192	128	1,2	●	2400	80	118	79	1,2	●
65 x 95	59	51	35	30	101	M8	30	8	41	41	4300	132	180	123	1,3	●	2600	80	109	74	1,3	●
70 x 110	71	61	46	40	119	M10	30	8	83	83	7500	214	203	129	2,2	●	4600	131	125	79	2,3	●
75 x 115	71	61	46	40	124	M10	30	8	83	83	8000	213	189	123	2,3	●	5000	133	118	77	2,4	●
80 x 120	71	61	46	40	129	M10	30	8	83	83	8500	213	176	117	2,4	●	5200	130	108	72	2,6	●
85 x 125	71	61	46	40	134	M10	30	10	83	83	11400	268	209	142	2,6	●	7000	165	128	87	2,7	●
90 x 130	71	61	46	40	139	M10	30	10	83	83	12000	267	196	136	2,7	●	7400	164	121	84	2,8	●
95 x 135	71	61	46	40	144	M10	30	10	83	83	12600	265	185	130	2,8	●	7800	164	115	81	2,9	●
100 x 145	80	68	52	45	155	M12	35	8	145	145	15000	300	177	122	3,9	●	9800	196	116	80	4,1	●
110 x 155	80	68	52	45	165	M12	35	8	145	145	16500	300	161	114	4,2	●	10700	195	104	74	4,4	●
120 x 165	80	68	52	45	175	M12	35	10	145	145	22500	375	184	134	4,5	●	14600	243	120	87	4,7	●
130 x 180	80	68	52	45	188	M12	35	12	145	145	29000	446	202	146	5,5	●	19000	292	133	96	5,7	●
140 x 190	90	76	58	50	199	M14	40	10	210	230	32000	457	173	128	6,6	●	23000	329	125	92	6,9	●
150 x 200	90	76	58	50	209	M14	40	12	210	230	41000	547	193	145	6,9	●	30000	400	141	106	7,2	●
160 x 210	90	76	58	50	219	M14	40	12	210	230	44000	550	182	139	7,4	●	32000	400	133	101	7,8	●
170 x 225	90	76	58	50	234	M14	40	14	210	230	54500	641	200	151	8,6	●	39000	459	143	108	9,0	●
180 x 235	90	76	58	50	244	M14	40	14	210	230	57500	639	188	144	9,1	●	41000	456	134	103	9,5	●
190 x 250	90	76	58	50	259	M14	40	15	210	230	65000	684	191	145	10,6	●	46400	488	136	104	11,1	●
200 x 260	90	76	58	50	269	M14	40	15	210	230	68000	680	180	139	11,2	●	48800	488	129	100	11,7	●

● Sizes of clamping elements available from stock.

¹⁾ These are the maximum screw tightening torques. They can be reduced by a maximum of 40 % of the above-mentioned figures with T, F_{ax}, P_W and P_N decreasing proportionately.

NEW
NEW

CLAMPEX®

Clamping nuts

KTR Precision joints