

Part. S0635

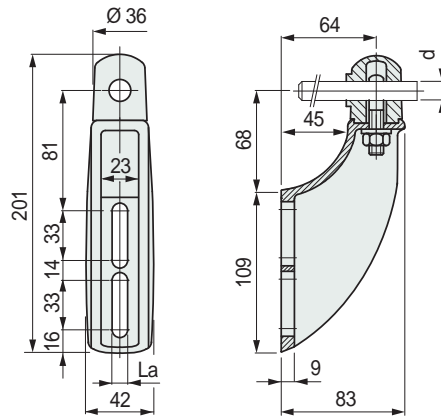

Adjustable bracket



Pin dia. d mm	Code		Weight kg
	La = 9 mm	La = 10,5 mm	
12	610893	648312	0,30
14	610903	648322	
16	610913	648332	

- Material: bracket and swivel head in reinforced Polyamide PA FV (black), eyebolt and tightening nut in austenitic stainless steel.
- Operation: by untightening the nut, the position of the top and the pin can be adjusted.
- Max recommended tightening torque: 4 Kgm.
- Packaging: 50 pieces.

Part. S0636



Adjustable bracket

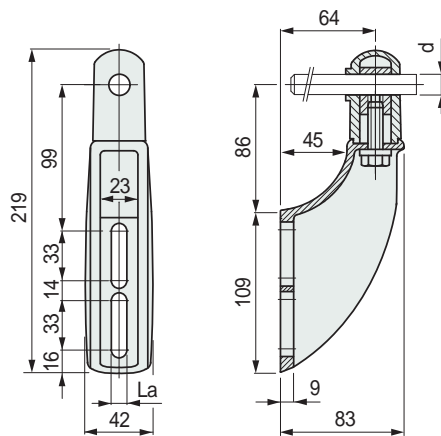

Pin dia. d mm	Code		Weight kg
	La = 9 mm	La = 10,5 mm	
12	610923	648342	0,30
14	610933	648352	
16	610943	648362	

- Material: bracket and swivel head in reinforced Polyamide PA FV (black), eyebolt in nickel plated brass, tightening screw in austenitic stainless steel.
- Operation: by untightening the screw, the position of the top and the pin can be adjusted.
- Max recommended tightening torque: 4 Kgm.
- Packaging: 50 pieces.

● Best Seller

● Standard

● On request: minimum quantity may apply. Consult our Customer Service for availability.

Item code for order = Part. + Code

Deflection of Part. S0635 - S0636

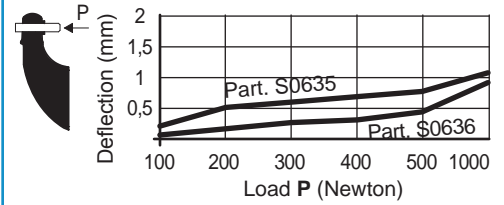

Technical data Part. S0635 - S0636

- Sliding load resistance:
- Breaking load:

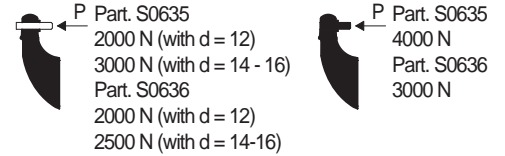

Tests performed at tightening torque: 4 Kgm

- Part. S0635 - S0636 permit application of 1 or more spacer Part. S0725.

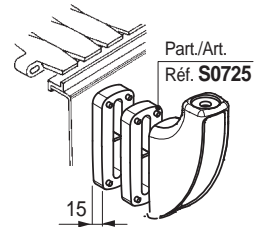

- Part. S0635 permit application of spacer Part. S0227.

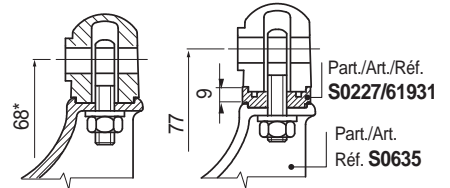

- * = To increase the height (by 9 mm) use 1 spacer Part. S0227 code 61931. The length of the thread allows for only 1 spacer.

- Part. S0636 permit application of spacer Part. S0227.

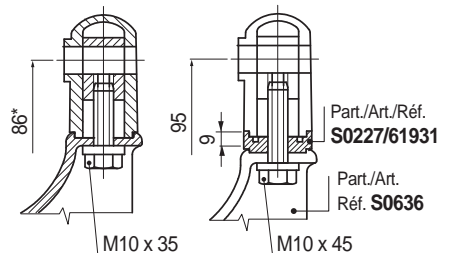

- * = To increase the height (by 9 mm) use 1 or more spacer Part. S0227 code 61931. To use the spacer it is necessary a longer screw.

- Part. S0226 - S0336. Part. S0635 and S0636 permit application of drip tray support.

Part./Art./Réf.
S0226 - S0336

