

• **Assembly with swivel head Part. S0255**

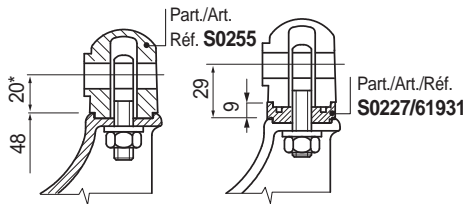

\* = To increase the height (by 9 mm) use 1 spacer Part. S0227 code 61931. The length of the thread allows for only 1 spacer.

• **Assembly with swivel head Part. S0359**

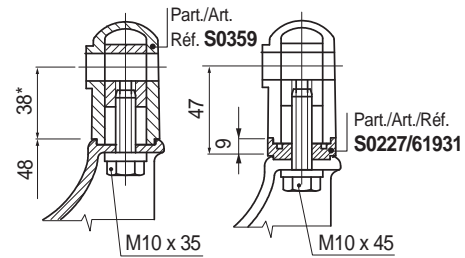

\* = To increase the height (by 9 mm) use 1 or more spacer Part. S0227 code 61931. To use the spacer it is necessary a longer screw.

• **Assembly with swivel head Part. S0256**

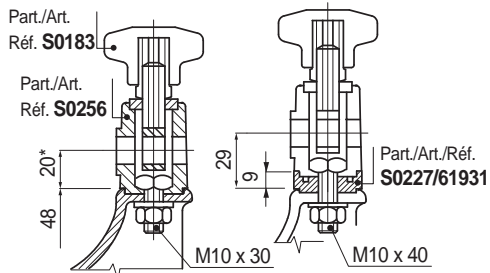

\* = To increase the height (by 9 mm) use 1 or more spacer Part. S0227 code 61931. To use the spacer it is necessary a longer screw.

• **Assembly with swivel head Part. S0192**

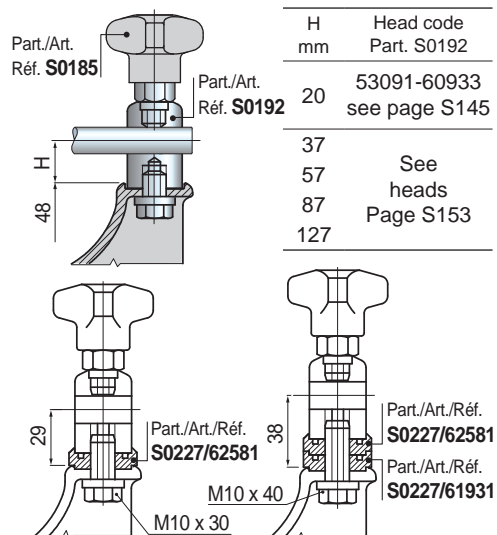

To use the spacer Part. S0227, it is necessary a longer screw.

■ **Adjustable bracket**

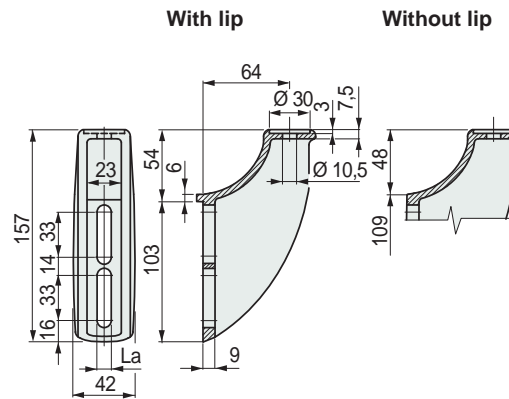

Version	Code		Weight kg
	La = 9	La = 10,5	
With lip	616843	616853	0,21
Without lip	605263	647142	

- Material: reinforced polyamide PA FV (black).
- Packaging: 50 pieces.
- Accessories: spacer Part. S0725.

Part. S0632



• **Assembly Part. S0632**

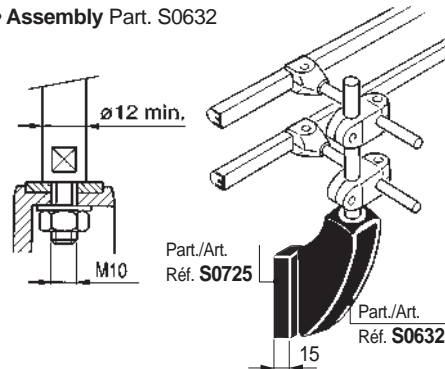

- Part. S0632 permit application of drip tray support Part. S0226 - S0336.

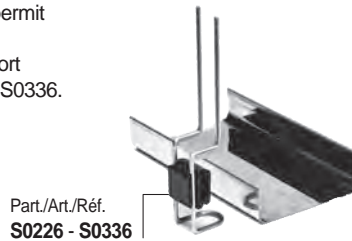

• **Deflection of Part. S0632**

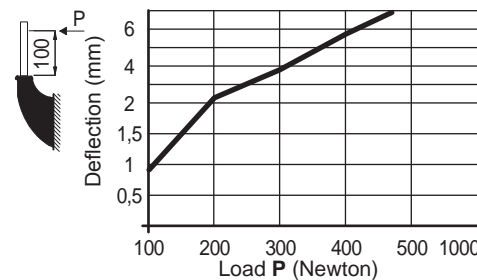

• **Breaking load P**

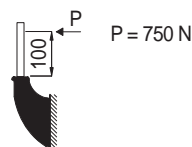

- **Best Seller**
- **Standard**
- **On request:** minimum quantity may apply. Consult our Customer Service for availability.

Item code for order = Part. + Code