

Part. S0628S

Roller side guide



Sideflexing

PATENTED

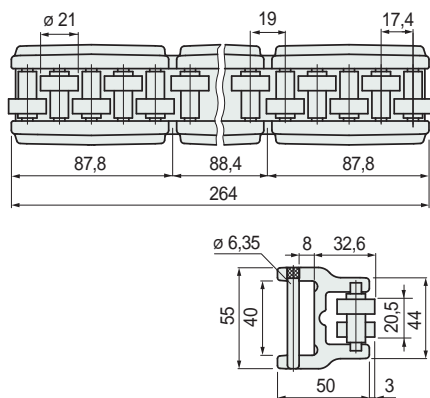

Version	Code	Weight kg
For 40x8 plate	671981	1,4

- Both straight and curved sections.
- Material: frame in polyamide PA (black).
Rollers in acetal POM (white).
Roller pins in ferritic stainless steel.
Fixing pins in austenitic stainless steel.
- Standard packaging: strands of 0,264 metres.
- Packaging: 6,336 metres (24 strands).
- Accessories:

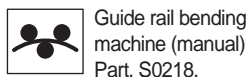
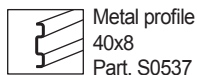

- **Use of Part. S0628 S**
Rugged containers (ex cases, cartons).

- **Fixing of Part. S0628 S**
Assembly / disassembly

- Fixing with plate.
- Fixing with metal profile Part. S0537.

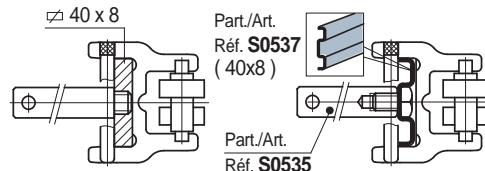

- **Assembly of Part. S0628 S**

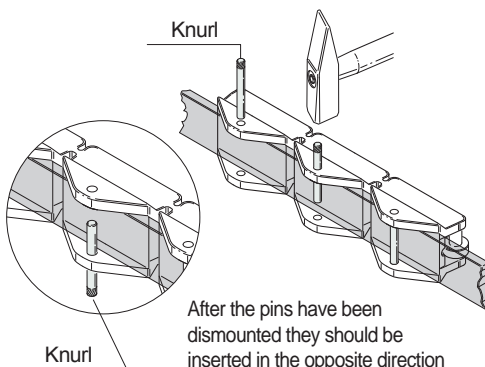

- **Deflection of Part. S0628 S**

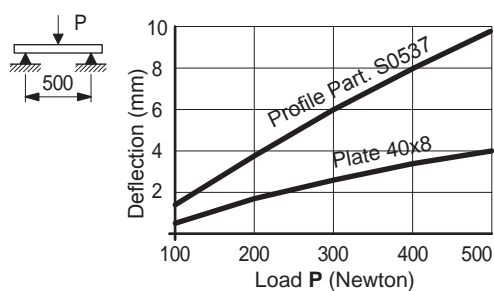

- **Min curvature radius Part. S0628 S**

For quick bending of metal profile Part. S0537, use the manual bending machine Part. S0218.

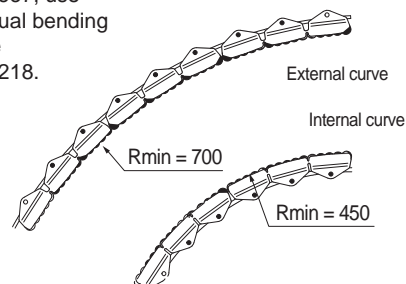

● Best Seller

● Standard

● On request: minimum quantity may apply. Consult our Customer Service for availability.

Item code for order = Part. + Code