

Part. S0619

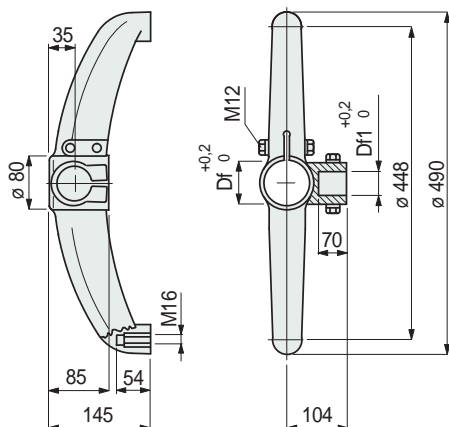

For round tubes

Support base (bipod)



Vertical tube dia. mm	Horizontal tube dia. mm	Bore dia. Df mm	Bore dia. Df1 mm	Code
-----------------------	-------------------------	-----------------	------------------	------

Bolts in austenitic stainless steel

42,4 (1 1/4")	42,4 (1 1/4")	42,4	42,4	624352
48,3 (1 1/2")	42,4 (1 1/4")	48,3	42,4	624372
48,3 (1 1/2")	48,3 (1 1/2")	48,3	48,3	692052
50,8	42,4 (1 1/4")	50,8	42,4	624402
60,3 (2")	42,4 (1 1/4")	60,3	42,4	624432

Bolts in zinc plated steel

42,4 (1 1/4")	42,4 (1 1/4")	42,4	42,4	638842
48,3 (1 1/2")	42,4 (1 1/4")	48,3	42,4	638852
48,3 (1 1/2")	48,3 (1 1/2")	48,3	48,3	600213
50,8	42,4 (1 1/4")	50,8	42,4	638862
60,3 (2")	42,4 (1 1/4")	60,3	42,4	638872

- Material: support base in reinforced polyamide PA FV (black), brass threaded bushings.
- Weight: 1,05 Kg.
- Max recommended tightening torque: 3,6 Kgm.
- Packaging: 12 pieces.

Assembly of Part. S0619

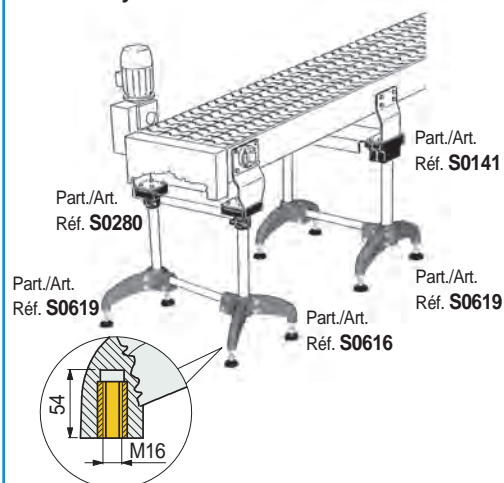

Detail of the insert for the levelers.

Sliding load

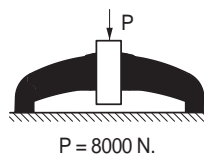

Max applicable load

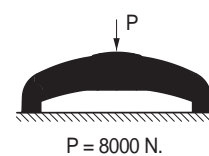

Deflection

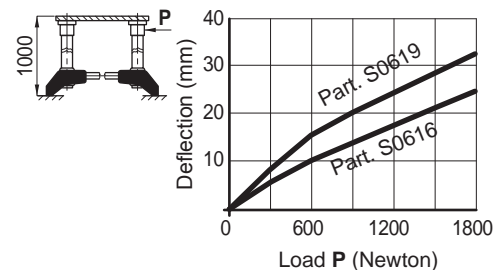

Tests performed at tightening torque: 3,6 Kgm

Types of levelers that can be used

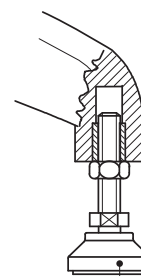

Part./Art./Réf. R0098 - R0133 - R0323

● Best Seller

● Standard

● On request: minimum quantity may apply. Consult our Customer Service for availability.

Item code for order = Part. + Code