

Part. S0562

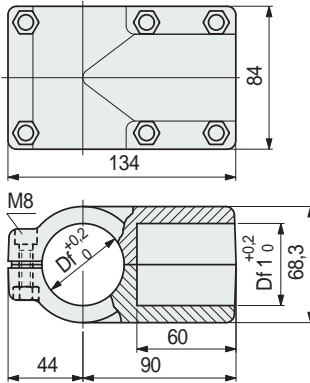

For round tubes

■ Connecting Joints



Vertical tube dia. mm	Horizontal tube dia. mm	Bore dia. Df mm	Bore dia. Df1 mm	Code
33,7 (1")	33,7 (1")	33,7	33,7	697831
38,1	33,7 (1")	38,1	33,7	605852
	38,1	38,1	38,1	697841
42,4 (1 1/4)	33,7 (1")	42,4	33,7	607092
	38,1	42,4	38,1	637353
	42,4	42,4	42,4	637343
48,3 (1 1/2)	33,7 (1")	48,3	33,7	605862
	38,1	48,3	38,1	697851
	42,4 (1 1/4)	48,3	42,4	607102
	48,3 (1 1/2)	48,3	48,3	697861

- Material: joint in reinforced polyamide PA FV (black). Tightening screws in austenitic stainless steel, nuts in nickel plated brass.
- Weight: 0,4 Kg.
- Max recommended tightening torque: 1,5 Kgm.
- Packaging: 8 pieces.

Part. S0563



For round tubes

■ Connecting Joints

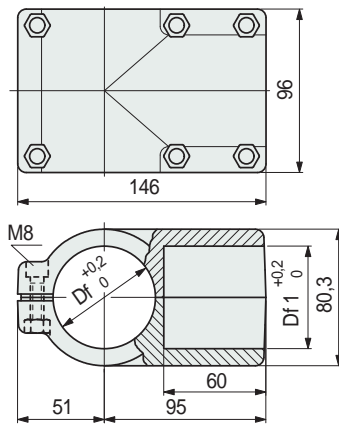

Vertical tube dia. mm	Horizontal tube dia. mm	Bore dia. Df mm	Bore dia. Df1 mm	Code
50,8	33,7 (1")	50,8	33,7	697871
	42,4 (1 1/4)	50,8	42,4	605892
	48,3 (1 1/2)	50,8	48,3	605872
60,3 (2")	50,8	50,8	50,8	669512
	33,7 (1")	60,3	33,7	605882
	42,4 (1 1/4)	60,3	42,4	605562
	48,3 (1 1/2)	60,3	48,3	697881
	60,3 (2")	60,3	60,3	697891

- Material: joint in reinforced polyamide PA FV (black). Tightening screws in austenitic stainless steel, nuts in nickel plated brass.
- Weight: 0,5 Kg.
- Max recommended tightening torque: 1,5 Kgm.
- Packaging: 8 pieces.

• Assembly of Part. S0562

Example of assembly with vertical tubes ø 33,7 mm

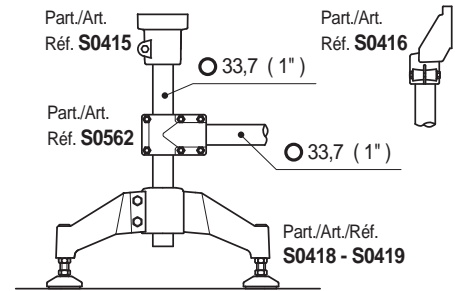

Example of assembly with vertical tubes ø 48,3 mm

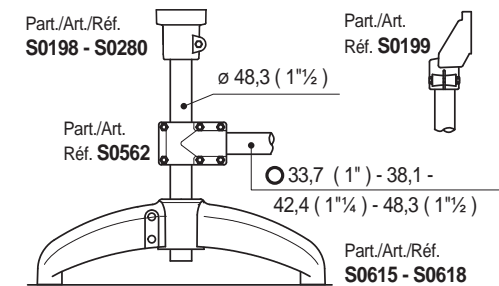

• Assembly of Part. S0563

Example of assembly with vertical tubes ø 60,3 mm

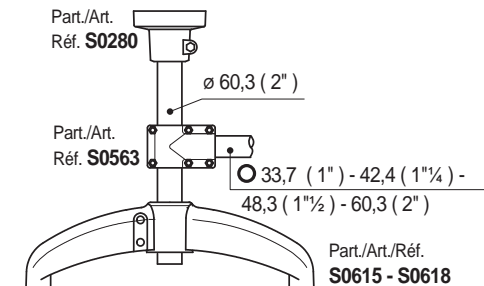

• Sliding load resistance

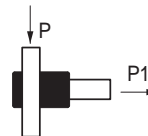

Part. S0562 (P = 2000 N) - (P1 = 3500 N)  
Part. S0563 (P = 1500 N) - (P1 = 3000 N)

Tests performed at tightening torque: 1,5 Kgm

● Best Seller

● Standard

● On request: minimum quantity may apply. Consult our Customer Service for availability.

Item code for order = Part. + Code