

Part. S0550

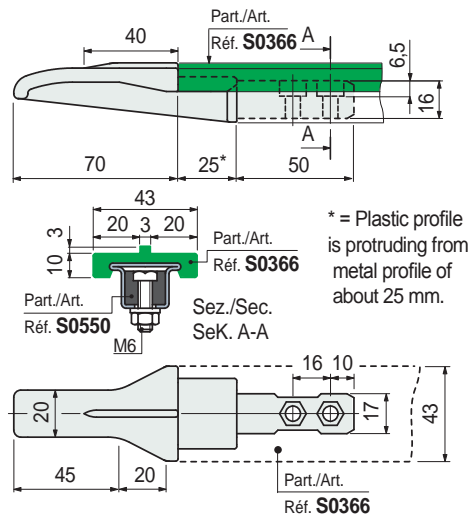

Chain inlet guide shoe (centre)



Code	Weight kg
689481	0,042

- Use: can be used in combination with Part. S0366.
- Material: polyamide PA (black).
- Packaging: 50 pieces.

Part. S0550



Chain inlet guide shoe (centre)

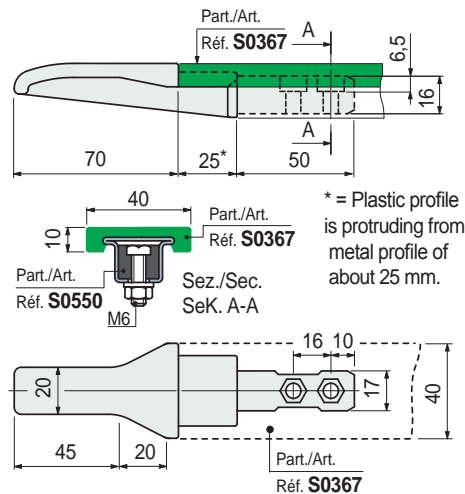

Code	Weight kg
689491	0,042

- Use: can be used in combination with Part. S0367.
- Material: polyamide PA (black).
- Packaging: 50 pieces

● Best Seller

● Standard

● On request: minimum quantity may apply. Consult our Customer Service for availability.

Item code for order = Part. + Code

In TableTop® conveyors, chain inlet guide shoes shall be used near the idlers.
In MatTop® conveyors can be used near the sprockets too.

- Chain width 82,5 mm (K325) / Pitch 88 mm.

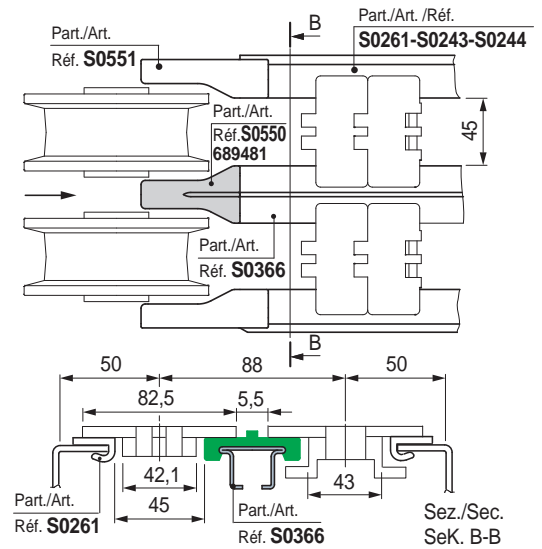

- Chain width 82,5 mm (K325) / Pitch 83,5 mm.

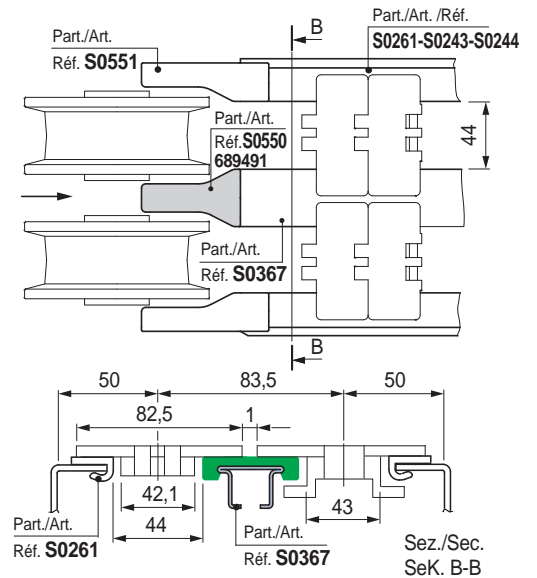

- Example of use of Part. 550 in a MatTop® conveyor.

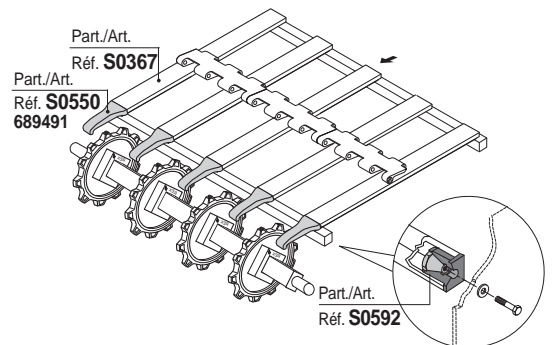

- Positioning

