

Chain width 114,3 mm (K 450) / Pitch 120 mm

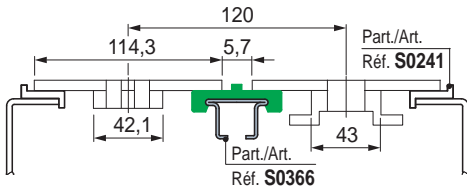

Chain width 152,4 mm (K 600) / Pitch 158 mm

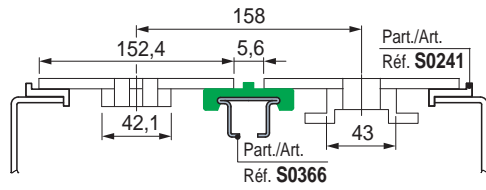

• **MatTop® modular chains**

Parallel wear strips.
Recommened with medium light loads.

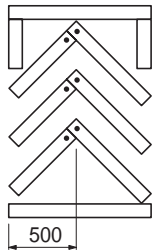
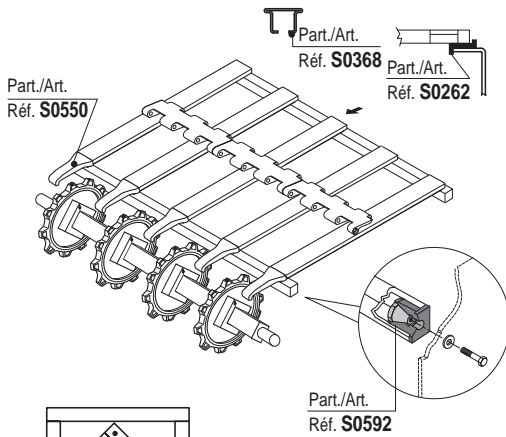
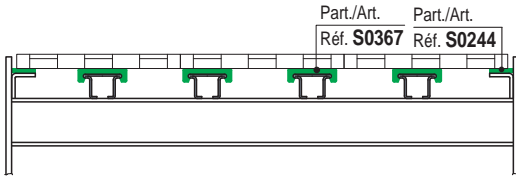

CHEVRON pattern.
Recommended with high loads
(accumulation tables).
Chain wear is evenly distributed
throughout the width.

■ **Mounting block**

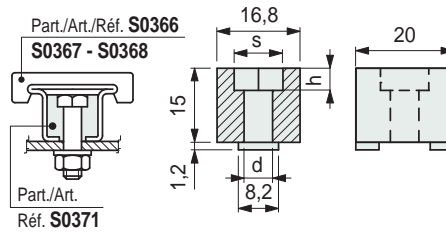

Part. S0371



d mm	h mm	Hexagon s mm	Code
6,2 (for screws M6)	4,5	10,2	64026
8,1 (for screws M8)	6	13,2	61056

- Use. easy assembly of wear strips on frame. Assembly with M6 or M8 hexagon bolt.
- Material. reinforced polyamide PA FV (black).
- Packaging. 100 pieces.

■ **Connecting block**

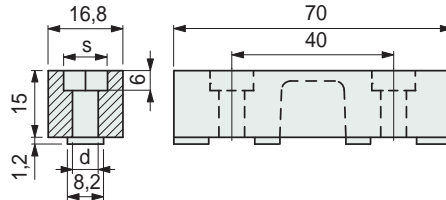

Part. S0621



d mm	Hexagon s mm	Code
6,2 (for screws M6)	10,2	670562
8,1 (for screws M8 - 5/16")	13,2	635542

- Use. easy connection of chain guide profiles Part. S0366 - S0367 - S0368. Assembly with M6 - M8 - 5/16" hexagon bolt.
- Material. reinforced polyamide PA FV (black).
- Packaging. 100 pieces.

- **Best Seller**
- **Standard**
- **On request:** minimum quantity may apply. Consult our Customer Service for availability.

Item code for order = Part. + Code