

Part. S0346

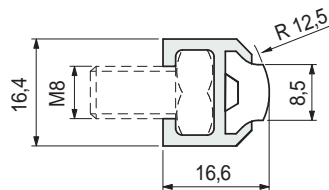

In aluminium

■ Guide rail (half round)



Length metres	Code	Weight kg/m
3	60204	0,24
6	60214	

- Colour: white.
- Metal profile in anodized aluminium.
- Min. curvature radius: 110 mm.
- Linear expansion coefficient: $2 \times 10^{-4} \text{ } ^\circ\text{C}^{-1}$.
- Calculation of thermal expansion see Technical information.
- Packaging: 48 metres (in 3 m length 10Ft).
96 metres (in 6 m length).
- Accessories:



Guide rail bending machine (manual)
Part. S0218.

- **Material:** Polyethylene UHMWPE with molecular density 5.600.000 g/mol.
Characteristics: new material Polyethylene ULF brown red (UHMWPE): reduced friction coefficient, higher wear resistance.
- **Operating temperature White, Green, Black:**
In air (- 40 to + 80 °C).
In hot water (+ 70 °C).
- **Operating temperature ULF - brown red:**
In air (- 40 to + 45 °C).
In hot water (+ 45 °C).
- **Polyethylene ULF is FDA approved**
Polyethylene ULF complies with the Code of Federal Regulations Title 21, § 177.1520 "Olefin Polymers" of the Food and Drug Administration (FDA) of April 1, 2008.

- **Use of Part. S0346**
Conveyors with limited lateral loads (ex brick).

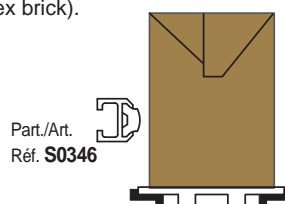

Part./Art.
Réf. **S0346**

- **Assembly of Part. S0346**

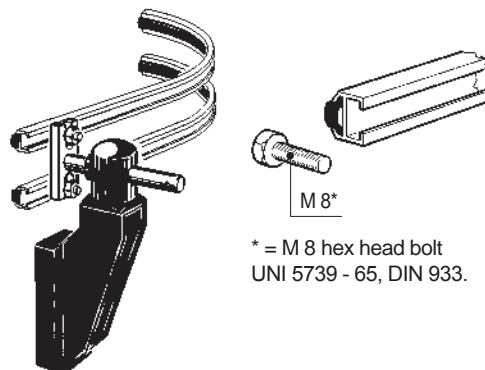

* = M 8 hex head bolt
UNI 5739 - 65, DIN 933.

- **Deflection of Part. S0346**

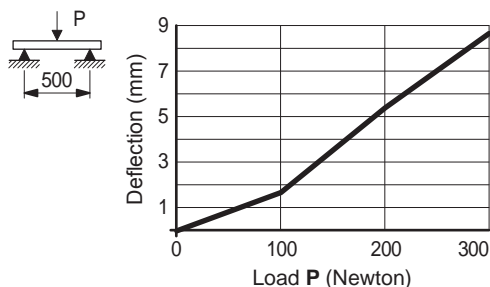

- **Assembly of Part. S0369**
Insert the guides and tighten the set screws.

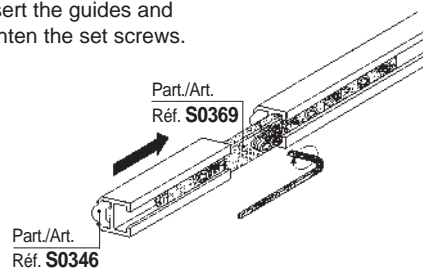

Part./Art.
Réf. **S0346**

● Best Seller

● Standard

● On request: minimum quantity may apply. Consult our Customer Service for availability.

Item code for order = Part. + Code