

- **Assembly** of Part. S0227 code 61931
Applicable to adjustable brackets.

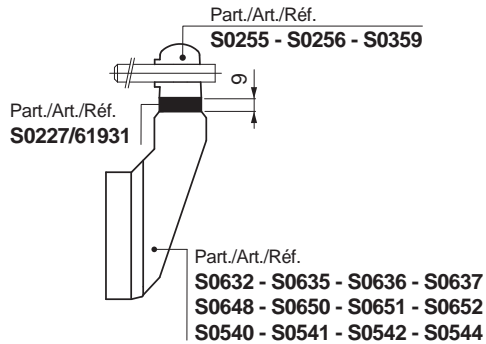

- **Assembly** of Part. S0227 code 62581
Applicable only to adjustable brackets
Part. S0543 - S0638 - S0653 (version with metal head).

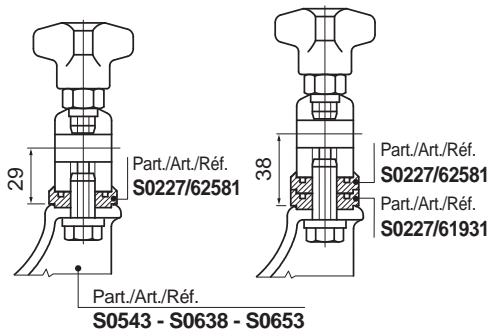

■ Spacer

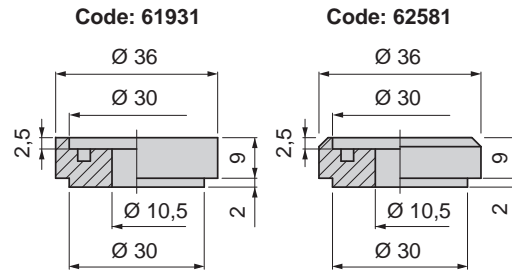

Use	Code	Weight kg
With any adjustable bracket or bearing head	61931	
For adjustable bracket Part. S0178 - S0543 - S0638 - S0653 or bearing head Part. S0192	62581	0,01

- Material: Reinforced polyamide PA FV (black).
- Packaging: 50 pieces.

Part. S0227



■ Eyebolt

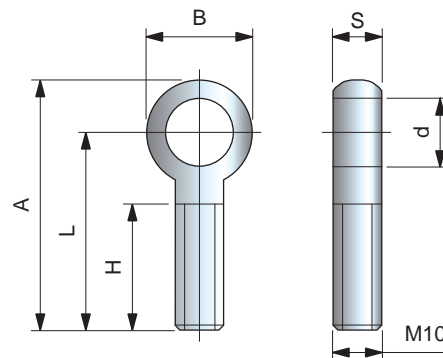

d mm	L mm	H mm	A mm	B mm	S mm	Code
	30	18	41	20	10	65624
13	40	30	51	21	10	69878
	45	35	56	21	10	65524
14,2	30	20	41	20	10	61005
	45	35	56	21	10	60995
16,2	44	32	56	24	10	65804
20,5	36	22	50	27	7,3	675902

- Material: austenitic stainless steel.

Part. S0000



● **Best Seller**

● **Standard**

● **On request:** minimum quantity may apply. Consult our Customer Service for availability.

Item code for order = Part. + Code