

Part. S0191

Part. S0296



■ Guide rail (extra-large)

Part. S0191

Part. S0296

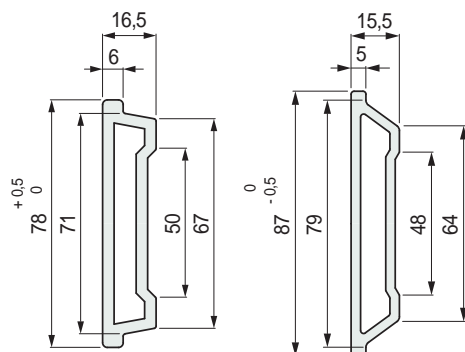

Material	Length metres	Code	Weight kg/m
Black	3	S019157131	0,60
	6	S019156811	
	3	S029668811	
	6	S0296618291	

- Material: polyethylene PE 500.000.
- Min. curvature radius: 200 mm.
- Linear expansion coefficient: $2,5 \times 10^{-4} \text{ }^\circ\text{C}^{-1}$.
Calculation of thermal expansion see Technical information.
- Packaging: 30 metres (in 3 m length).
60 metres (in 6 m length).
- Accessories:



Guide - Rail Clamps.



Guide rail bending machine (manual) Part. S0218.

Accessories

Part. S0376

Part. S0377



■ End plug

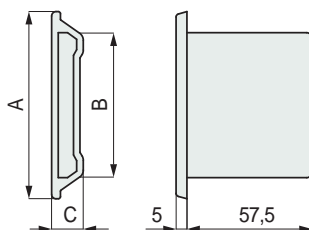

Use	A mm	B mm	C mm	Code
Applicable to Part. S0191	77	65,3	15,5	S037663626
Applicable to Part. S0296	86	63,8	14,5	S037763636

- Material: reinforced polypropylene PP FV (black).
- Packaging: 50 pieces.

● Best Seller

● Standard

● On request: minimum quantity may apply. Consult our Customer Service for availability.

Item code for order = Part. + Code

• Use of Part. S0191 - S0296

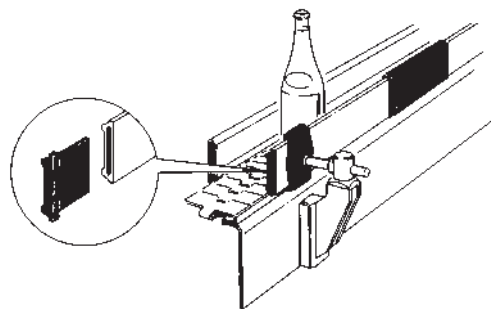

- The guide rails must be used with a 60 x 6 plate

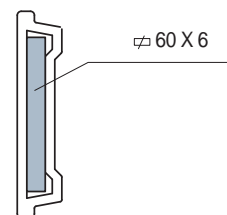

• Deflection of Part. S0191 - S0296

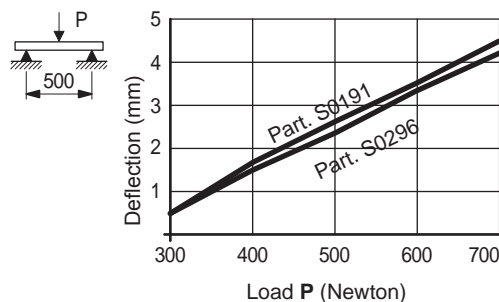

- Assembly of Part. S0376 - S0377
Press-fit.
Seal with silicon.

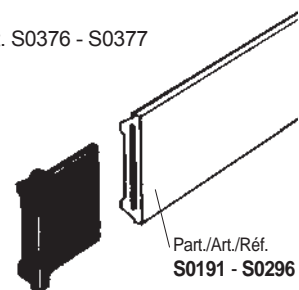

- Leave a gap between the plug and the plate to allow for contraction at low temperatures.

