

# Part. S0153

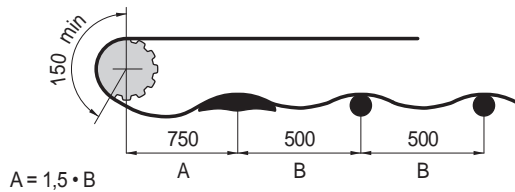

## Snap-on assembly

### Positioning



### Assembly

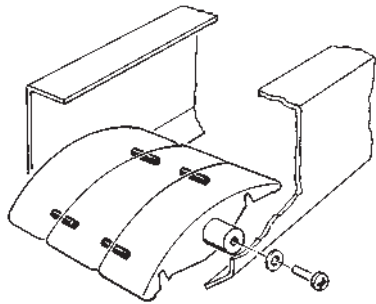
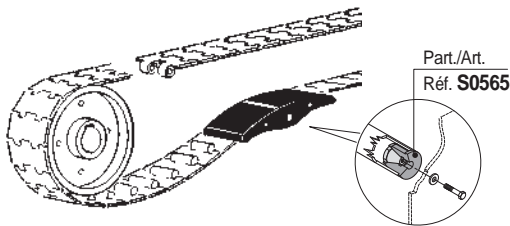

Shoes can be pinned together

### TableTop® chains / PlateTop chains

Chain width 82,5 mm (K 325)

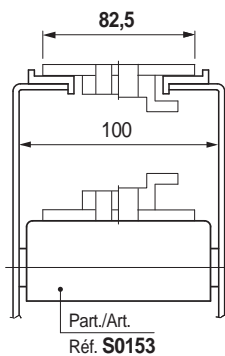

Chain width 82,5 mm (K 325) / Pitch 88 mm

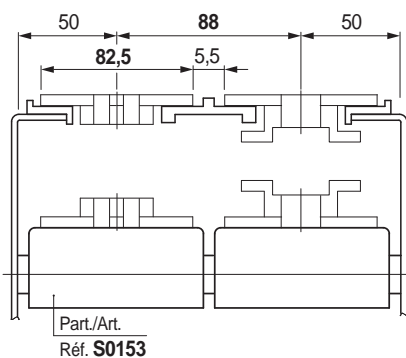

### Wear shoe

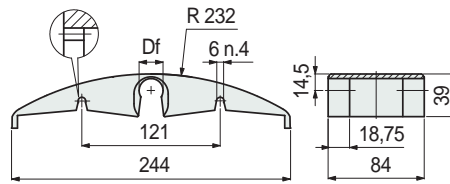

Shaft dia. mm	Bore dia. Df mm	Material	Code
18	18,5	UNL™ (aubergine)	609423N1
		Polyethylene PE (green)	608692N1
		Polyamide PA (black)	684221N1
20	20,5	Polyethylene PE (green)	684231N1
		UNL™ (aubergine)	609433N1

- New UNL™ low noise material is recommended only with LBP chains.
- PE polyethylene (green) version is recommended with plastic chains and metal chains.
- PA polyamide (black) version is recommended only with metal chains.
- The use of only one wear shoe after the catenary is recommended, with the exception of LBP chains that can run on more wear shoes.
- Packaging: 15 pieces.

Chain width 82,5 mm (K 325) / Pitch 85 mm

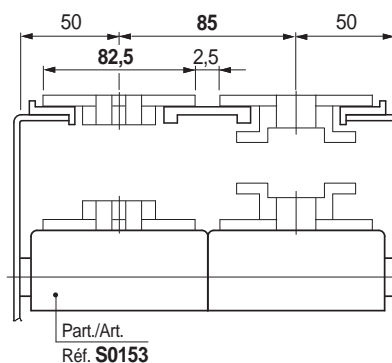

- Best Seller
- Standard
- On request: minimum quantity may apply. Consult our Customer Service for availability.

Item code for order = Part. + Code