

Characteristics of Part. S0786

Are indicated for end-line applications, to support centre guide or dividers, to separate and align containers before packing area.

Use of Part. S0786 (for square and round tubes)

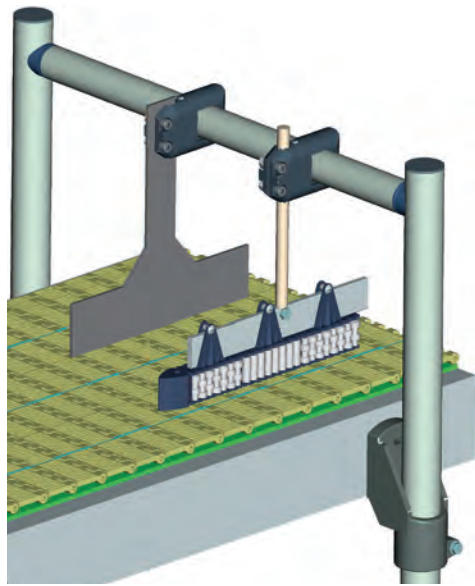
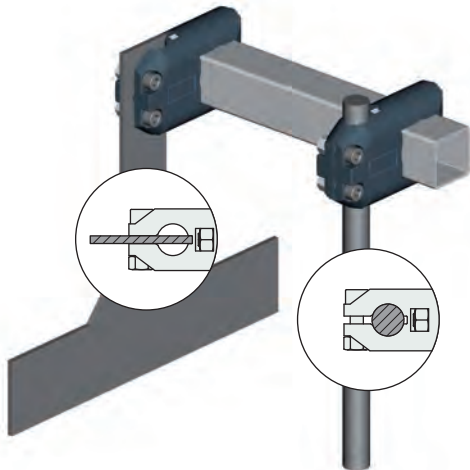

Use of Part. S0786 (for square and round tubes)

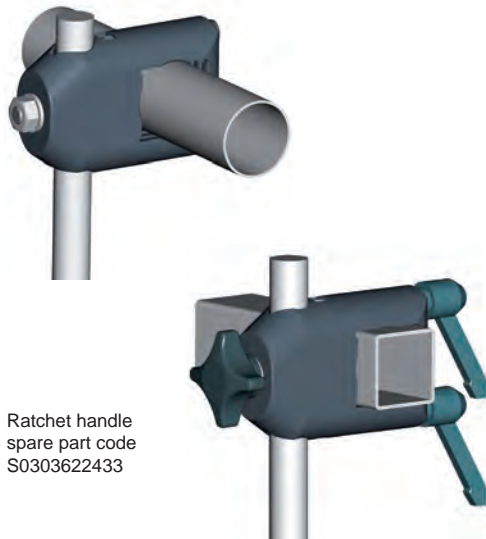

Ratchet handle
spare part code
S0303622433

Cross clamp

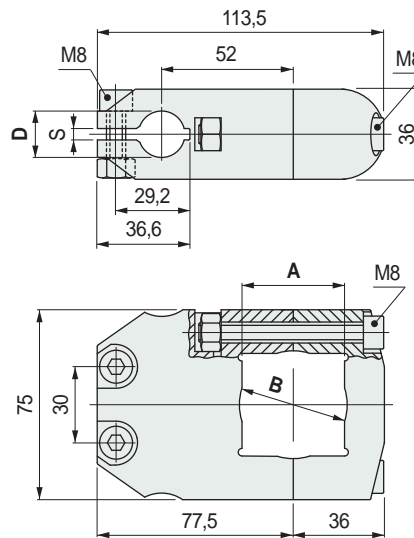

Square tube A mm	Round tube B mm	Round rod D mm	Plate S mm	Code	Weight kg
40	42,4	20	4	621783	0,27

- Material: clamp in reinforced polyamide PA FV (black), tightening screws in austenitic stainless steel, nuts in nickel plated brass.
- Max recommended tightening torque: 2 Kgm.
- Packaging: 25 pieces.

Part. S0786



Cross clamp

With nut

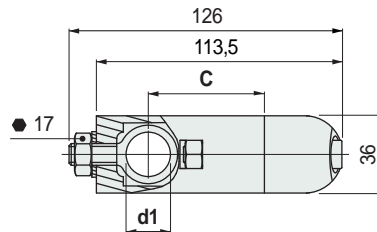

With knob and ratchet handles

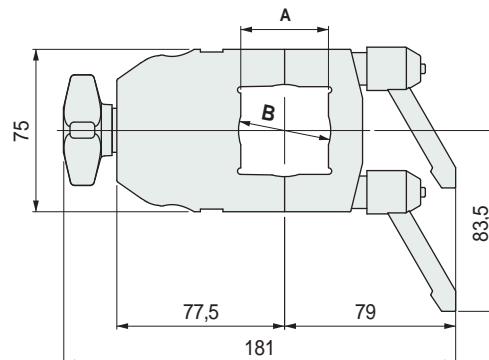

Square tube A mm	Round tube B mm	Rod dia. C mm	d1 mm	Code	Weight kg
40	42,4	55	15-16	618383	0,30
		52	20	618393	0,30

- Material: clamp in reinforced polyamide PA FV (black), tightening screws in austenitic stainless steel.
- Ratchet handle: handle in reinforced polyamide in PA FV (black), spindle in zinc plated steel.
- Max recommended tightening torque: 2 Kgm.
- Packaging: 25 pieces.

Part. S0786



● Best Seller

● Standard

● On request: minimum quantity may apply. Consult our Customer Service for availability.

Item code for order = Part. + Code